

PROGRAMME MASSING AND USER ANALYSIS

User Group	Needs	Programme
Taxi & Bus Operation	Taxi Space Eating / rest space Clean vehicles Planning space	Parking Shisanyama Washing bays Offices
Early Childhood Development Centre	Education Cooking Playing Storage Napping	Classrooms Kitchen Outdoor jungle gym Lockers + store room Nap rooms
Vocational Training	Education Knowledge Skills development Computer access	Lecture rooms Library Workshops Computer labs
Market Spaces	Cooking Cleaning Flexible trading Eating Refuse	Braais + prep station Washup area Adaptable trading spaces Seating area Bin / recycling room
Performance	Viewing space Comfortable environment Performance area Food & drink	Seating / benches Shading Platform / stage Market access
Sports centre	Viewing space Comfortable environment Food / drinks Rest Cleaning Training Equipment storage	Seating / benches Shading Platform / stage Seating Showers & change room Gym Storage rooms

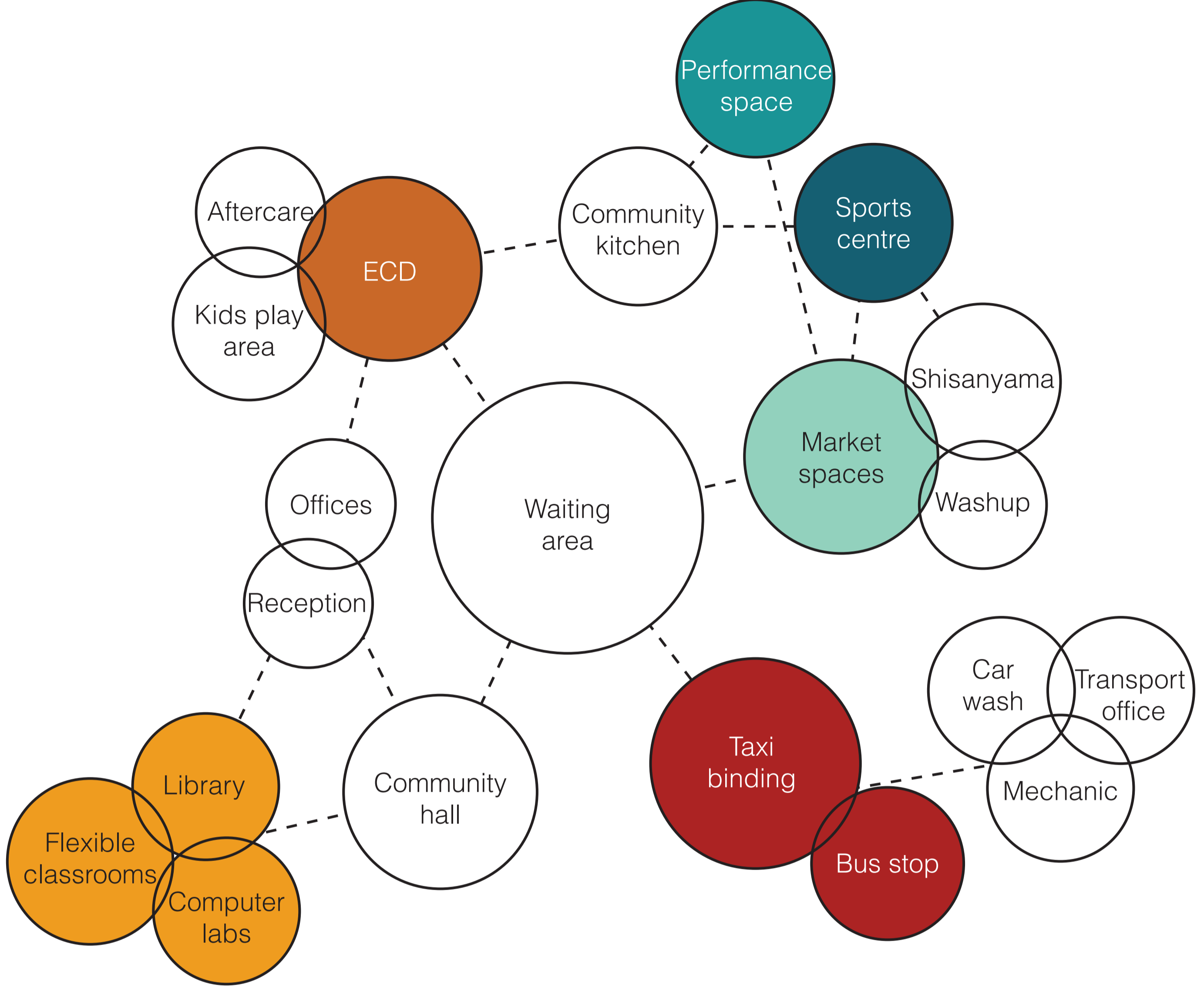

Taxi / Bus Transport

- 40m² Seating + Shelter
- 30m² Refuse Room
- 30m² Washing Station
- 30m² Service Station
- 6m² Office
- 15m² Classroom
- 20m² Ablutions

141m² Total

ECD

- 9m² Student Ablutions
- 6m² Staff Ablutions
- 8m² Staff Room + Kitchennette
- 30m² 4x Classrooms
- 250m² Playground
- 6m² Store Rooms
- 15m² Kitchen (shared with V Training)
- 20m² Nap Room
- 4m² Changing Room

423m² Total

Vocational Training

- 18m² 6x Classrooms
- 6m² 2x Meeting Rooms
- 50m² Computer Labs
- 50m² Library (shared with ECD)
- 15m² Kitchen
- 5m² 6x Offices
- 20m² Outdoor Lecture Space
- 8m² Staff Room + Kitchennette
- 200m² Outdoor/Indoor Seating (shared with Culture Centre)
- 20m² Ablutions

193m² Total

Market / Trade

- 5m² 20x Stalls
- m² Lock up spaces
- 20m² Ablutions
- 30m² Refuse Room (recycling sort)
- 20m² Ablutions
- 200m² Courtyard / spill out / performance

175m² Total

Cultural Centre

- 200m² Performance
- 12m² 2x Meeting Rooms
- 5m² 3x Offices
- 30m² Reception (foyer)
- 20m² Recording Studio
- 8m² Instrument Storage (lockup)
- 18m² 3x Classrooms
- 25m² Ablutions
- 3m² Storeroom
- 200m² Spill out space

567m² Total

Sports Centre

- 450m² 2x Netball Field
- 7000m² 3x Football Fields
- 40m² Changing Rooms
- 18m² Ablutions
- 3m² Store Room (cleaning)
- 10m² Store Room (equipment)
- 40m² Gym
- 12m² Meeting Room
- 6m² 2x Classrooms

135m² Total (excl fields)

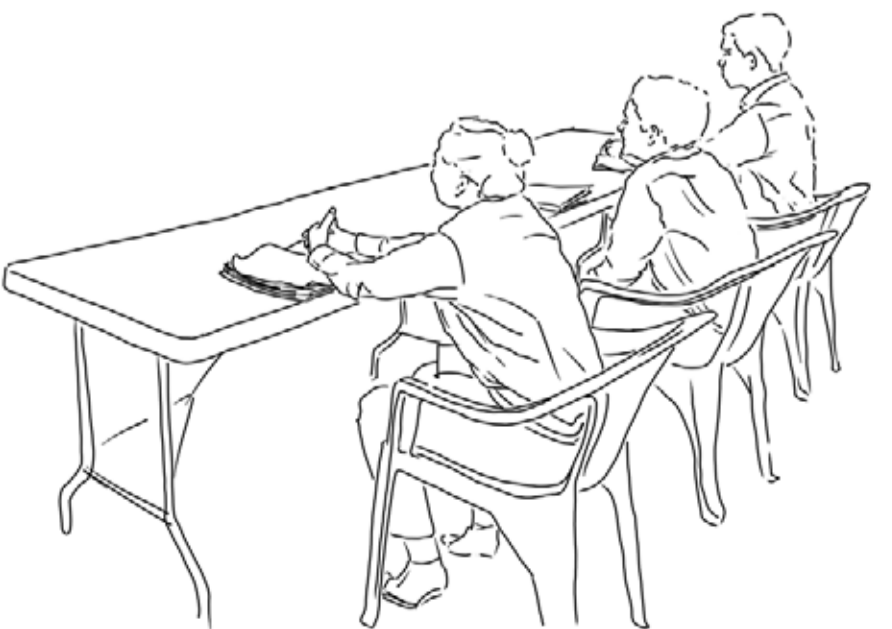

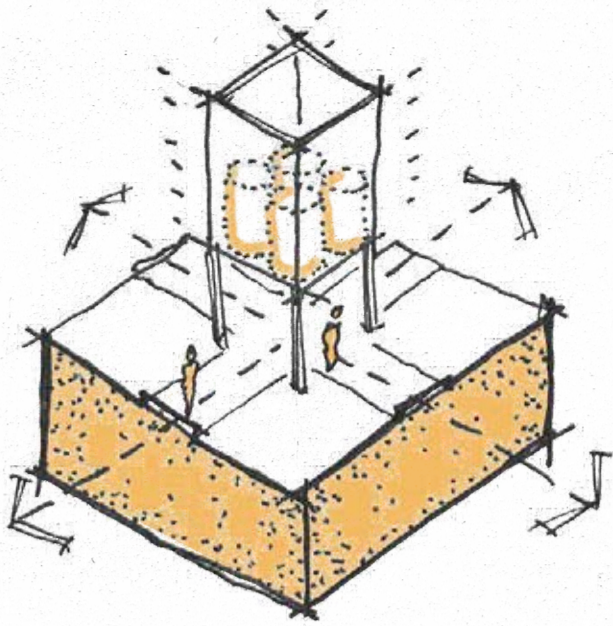

Water Collection

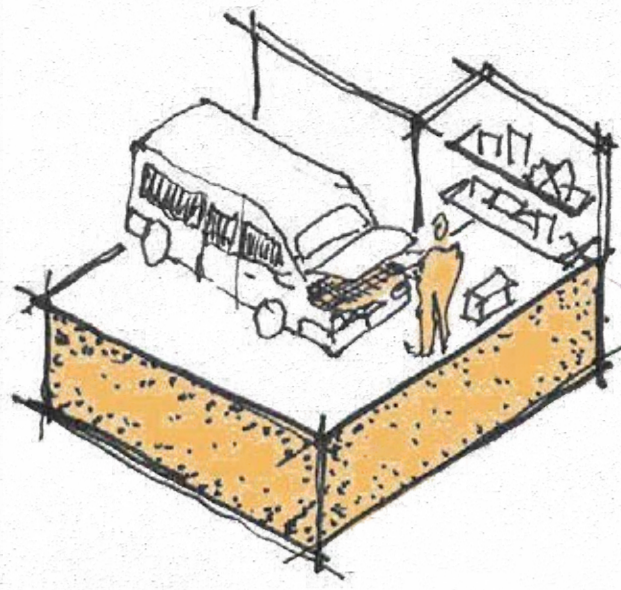

Mechanic Workshop

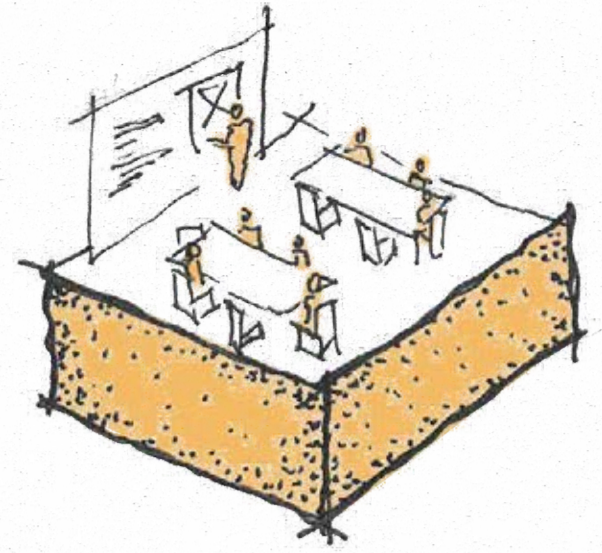

Private Education Spaces

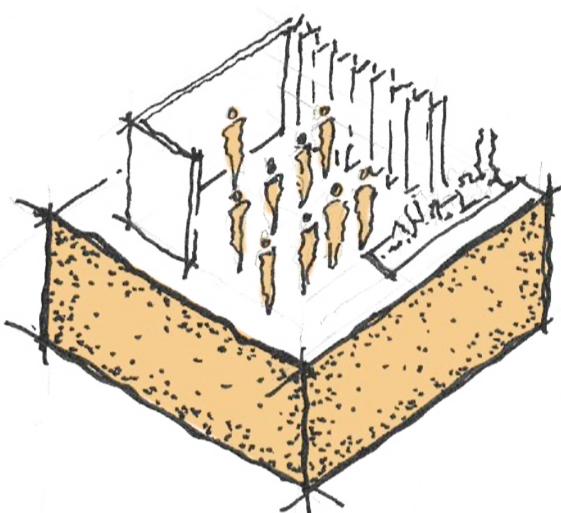

Community Meeting Spaces

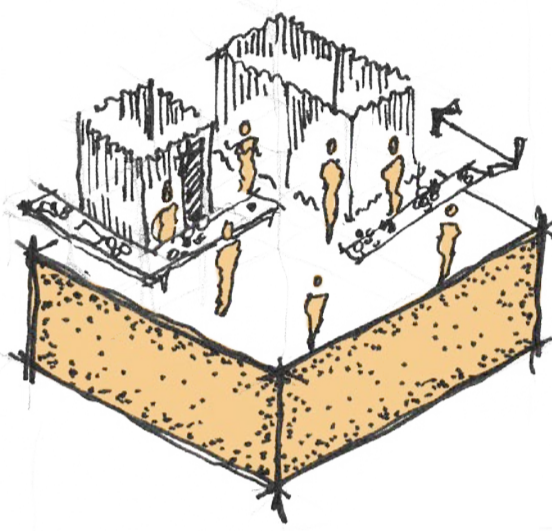

Trading and Markets

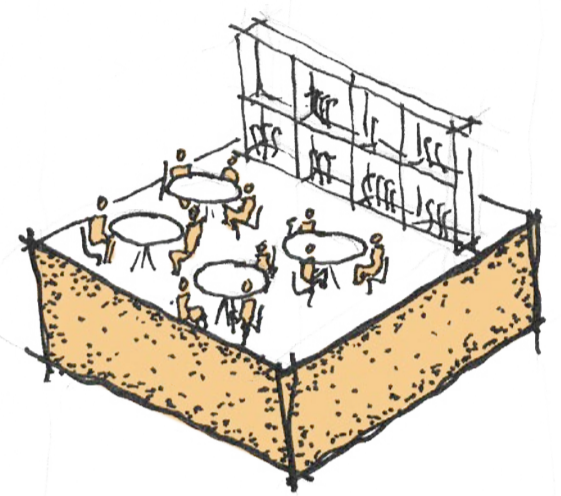

Resource Spaces

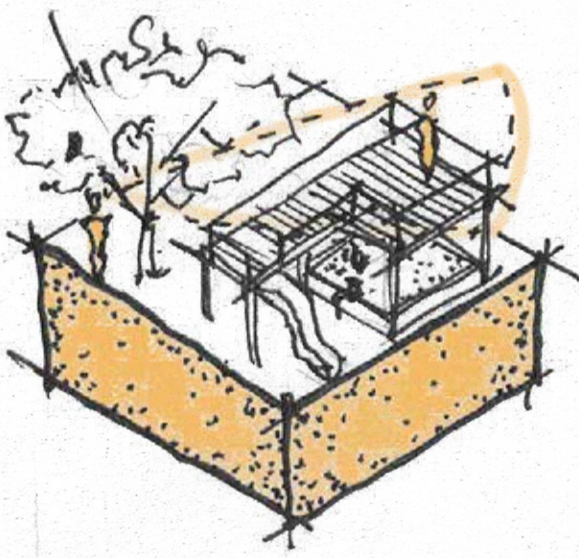

Play Areas

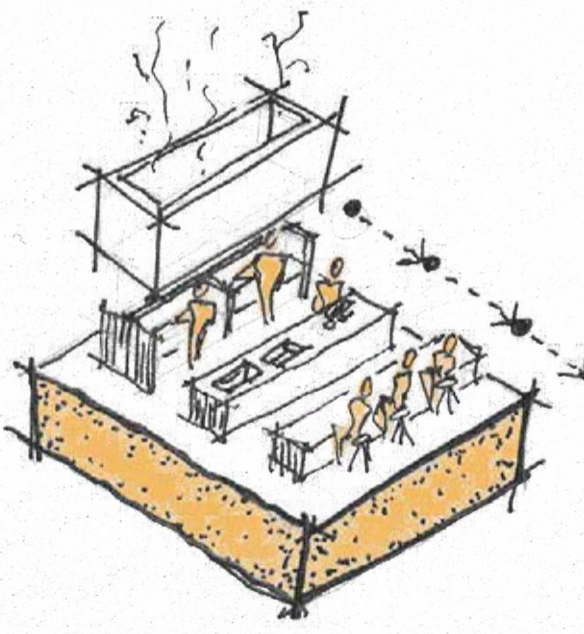

Food Preparation

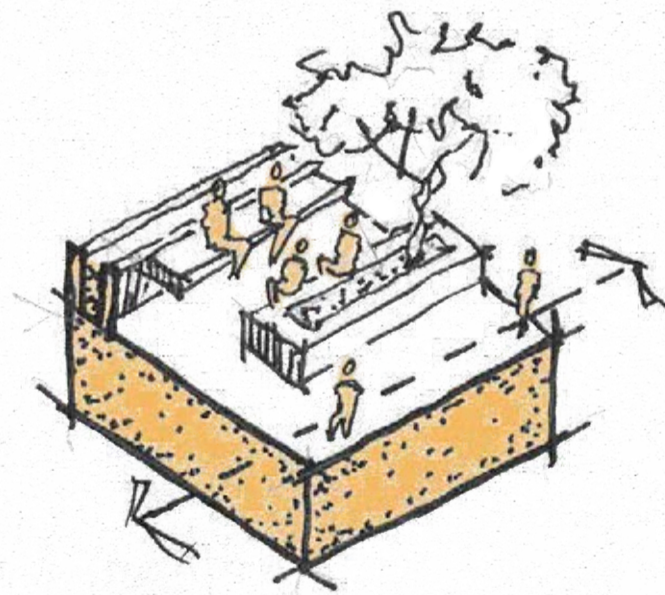

Gathering Spaces

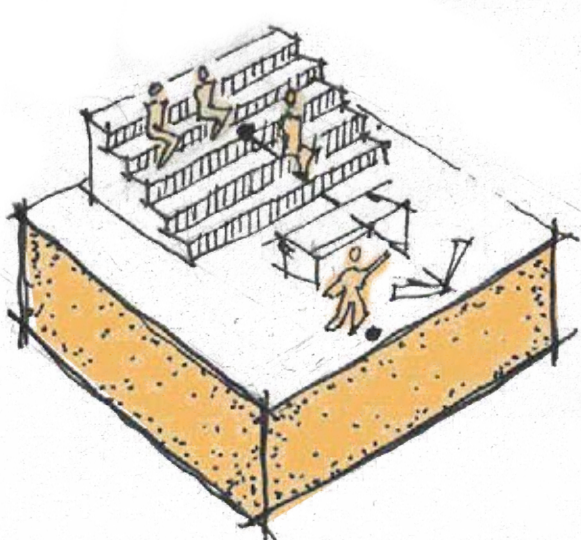

Sports Viewing

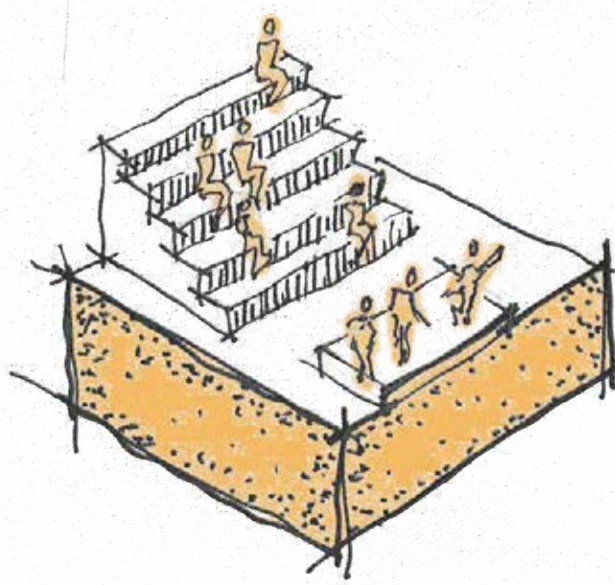

Public Events Spaces

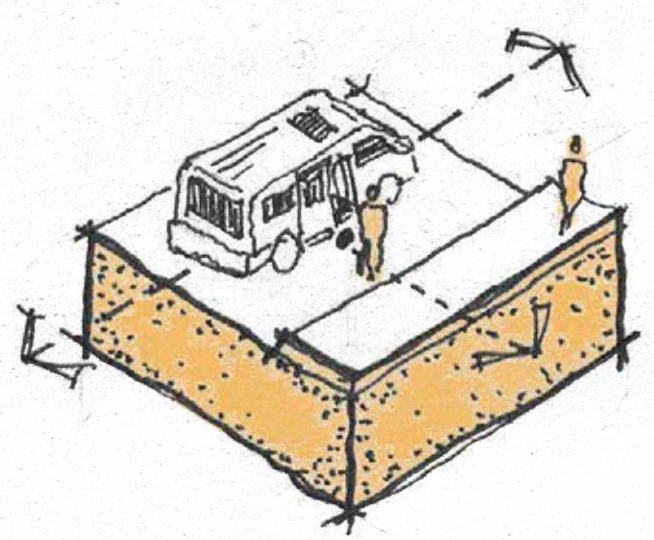

Taxi Binding and Arrival Spaces

DESIGN DEVELOPMENT

SCALED SPATIAL PROGRESSION

SITE SCALE

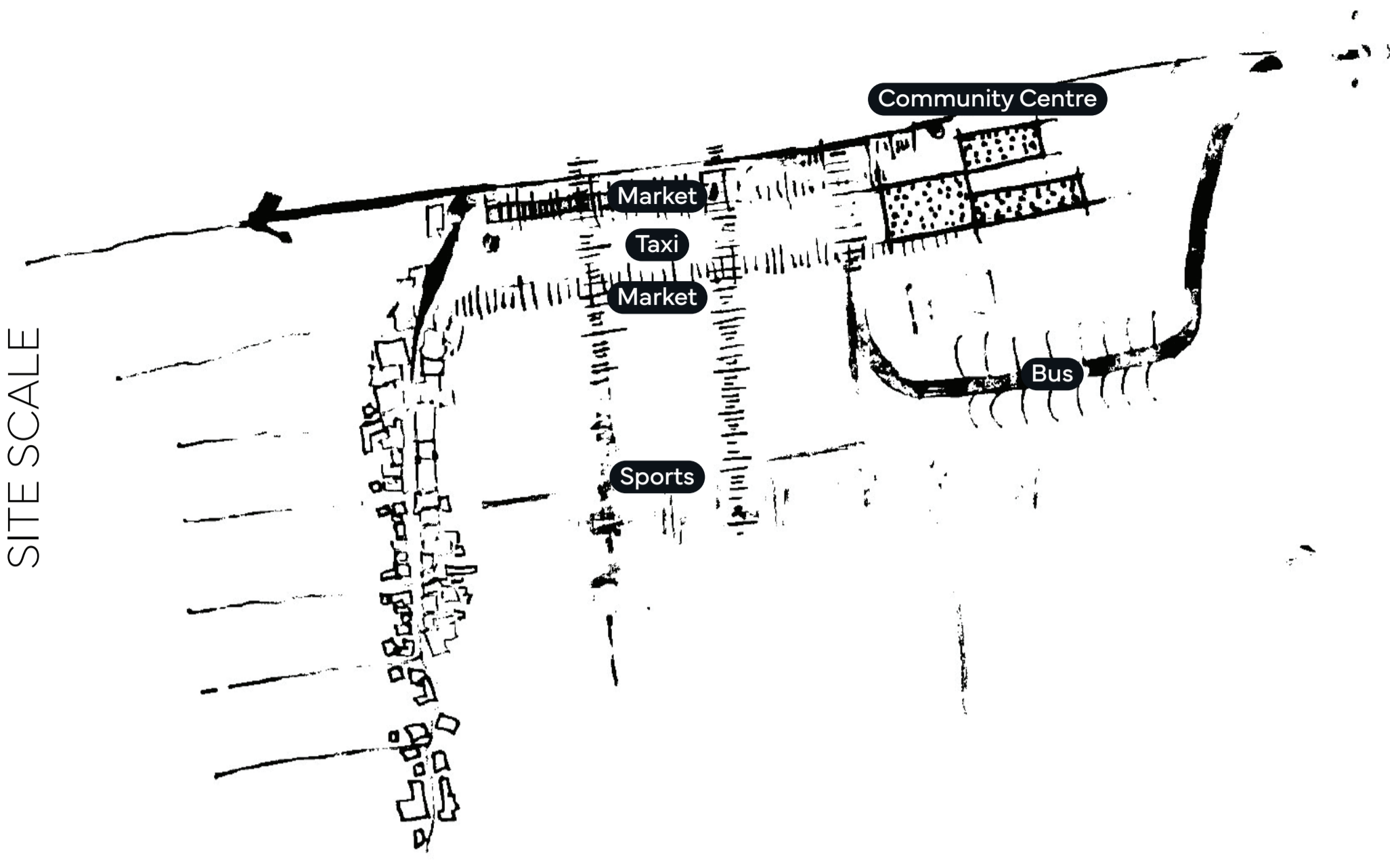

BUILDING SCALE

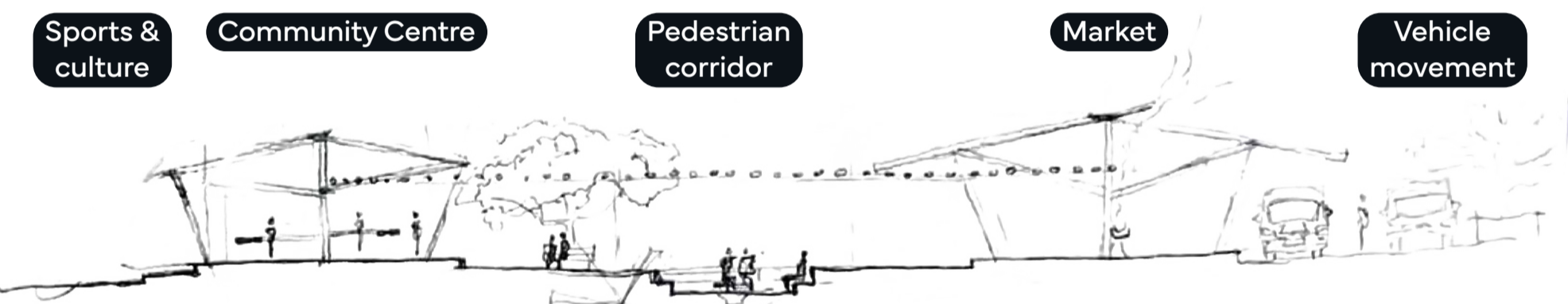

FACADE SCALE

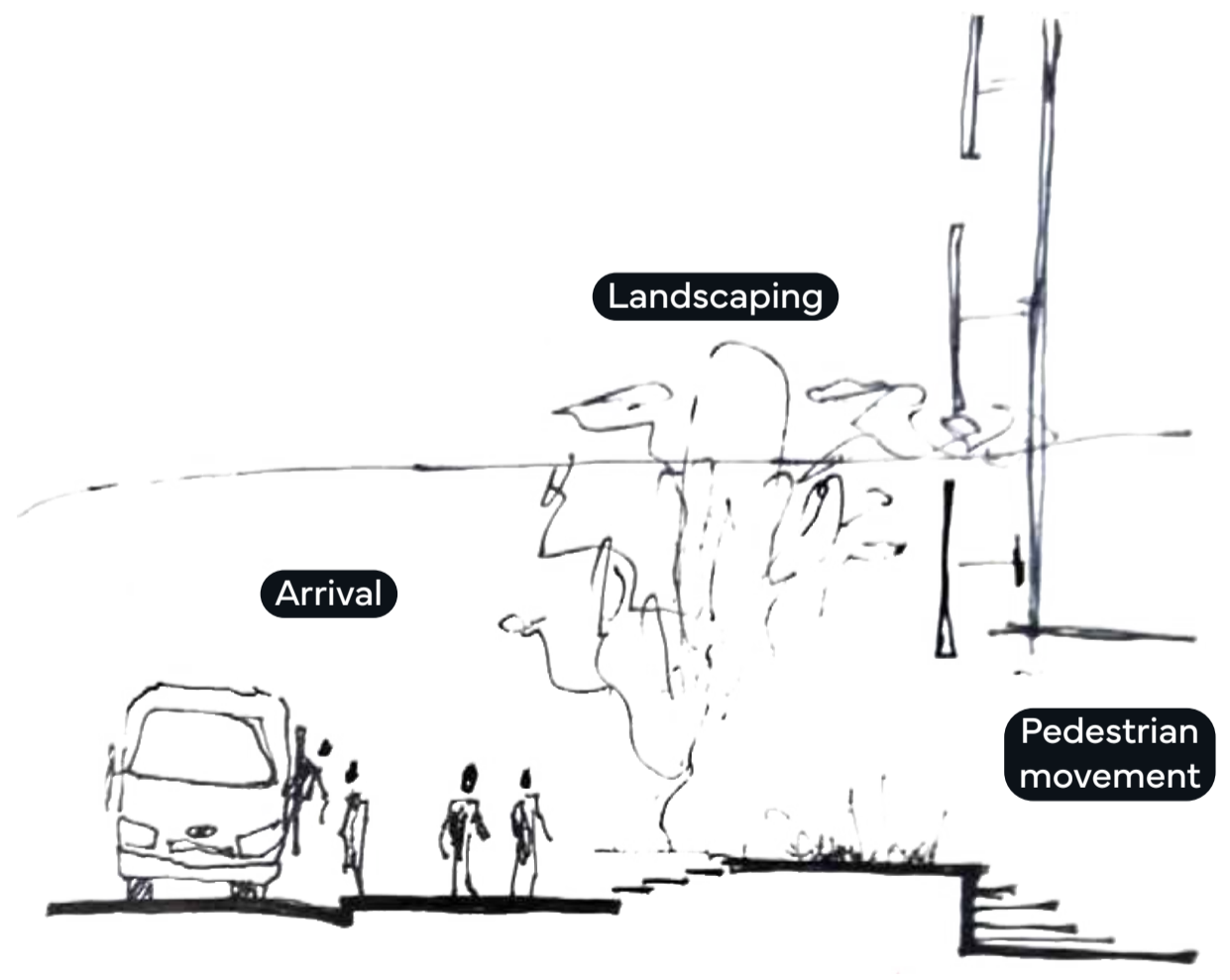

HUMAN SCALE

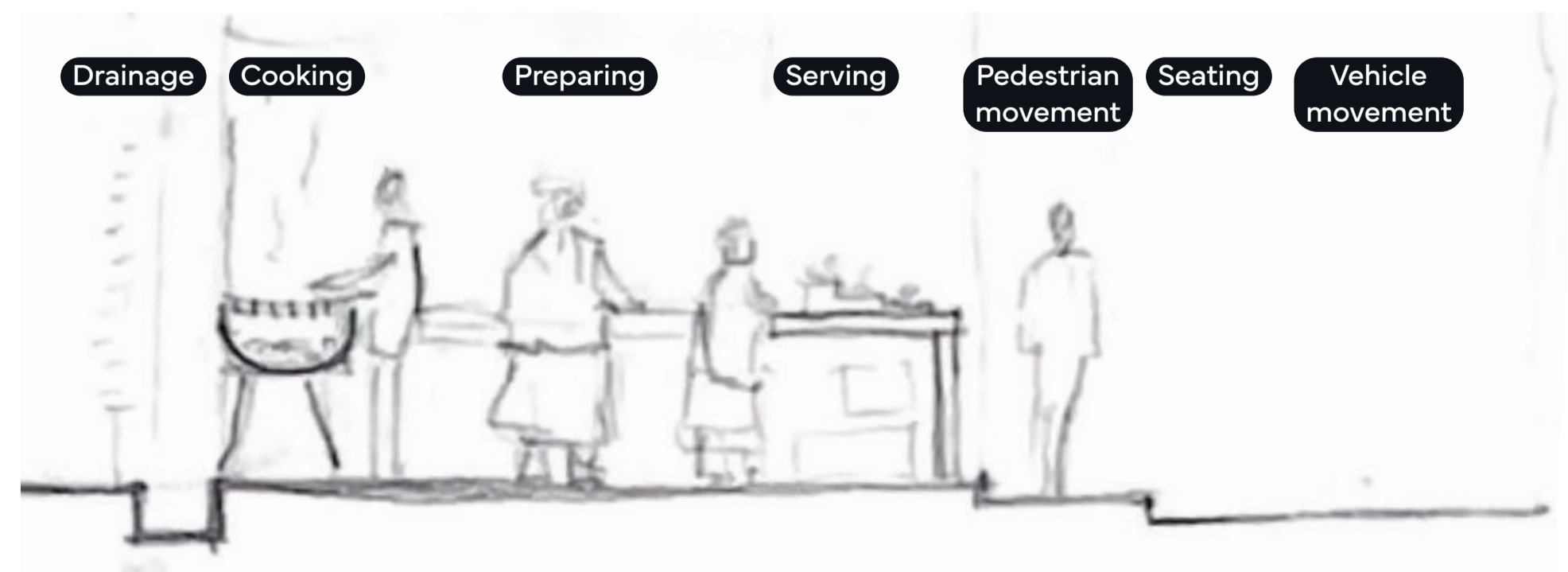

ZONING

- Taxi & Bus Operation
- Early Childhood Development Centre
- Vocational Training
- Market Spaces
- Performance
- Sports centre

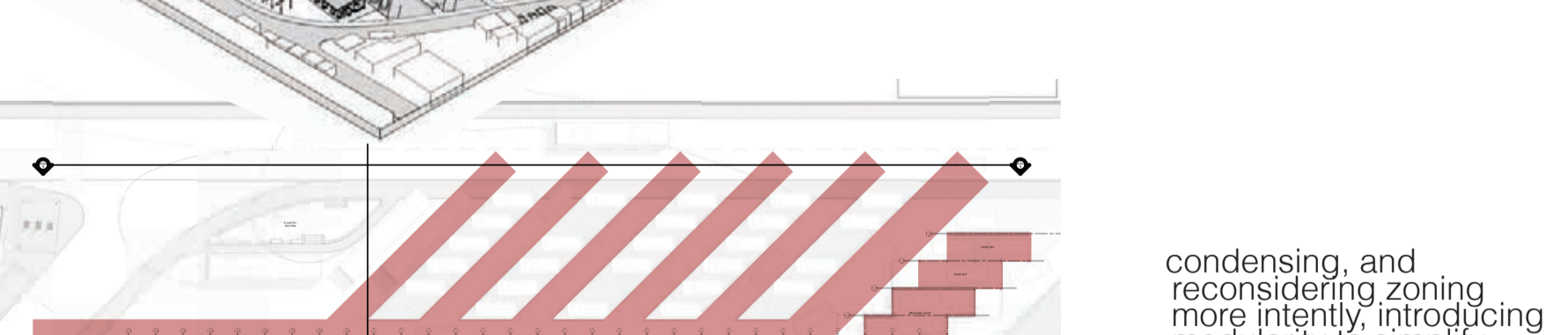
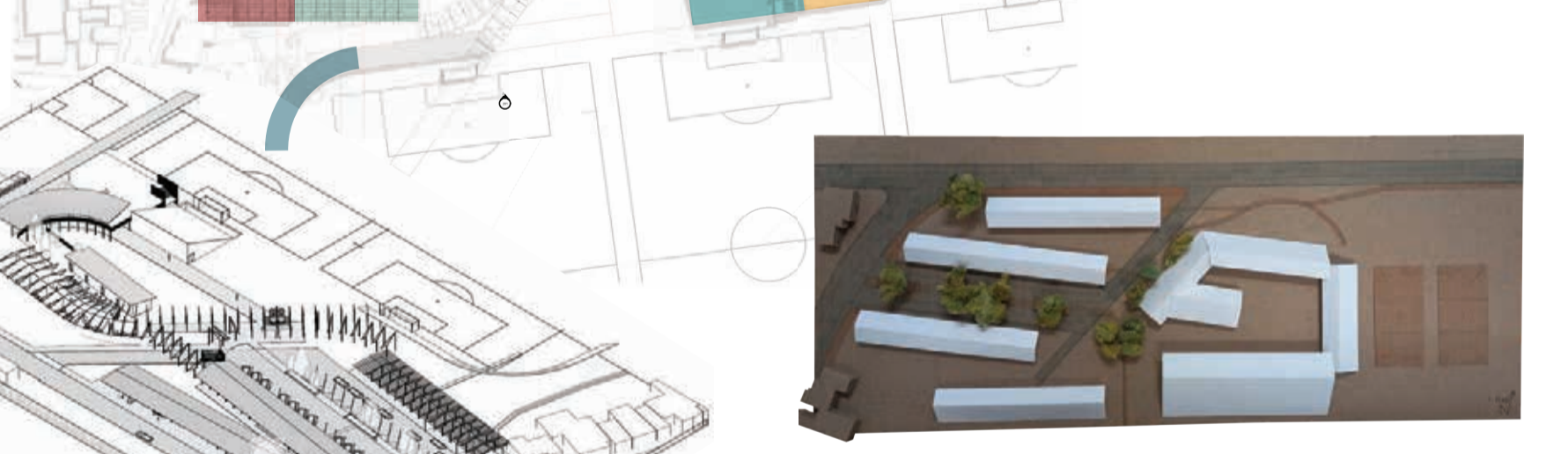
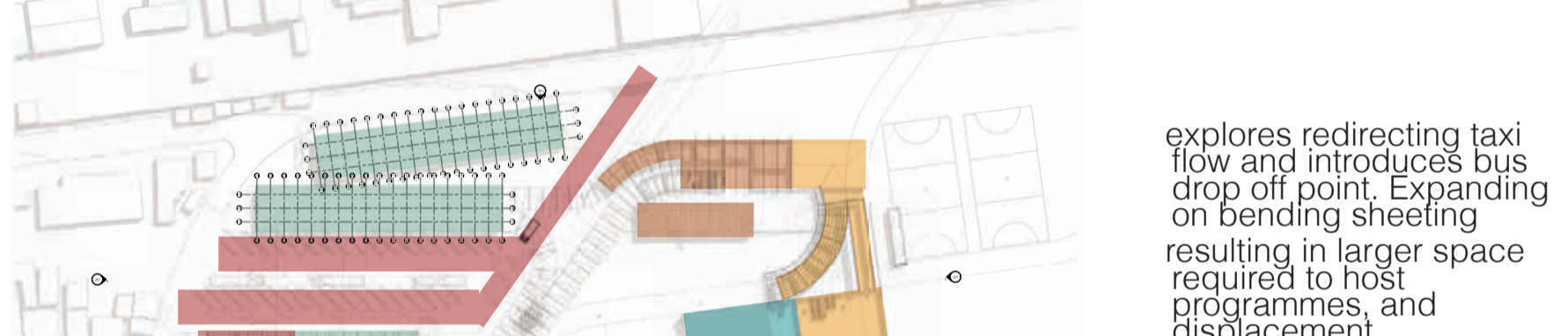
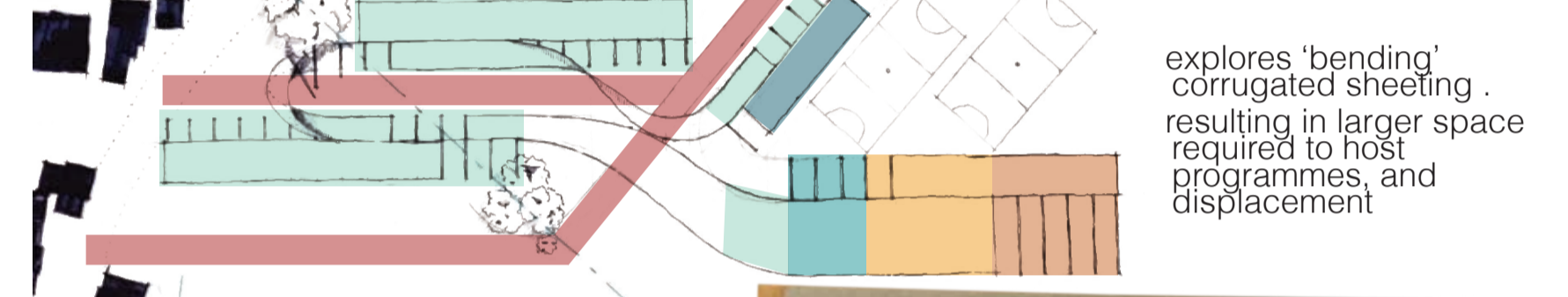
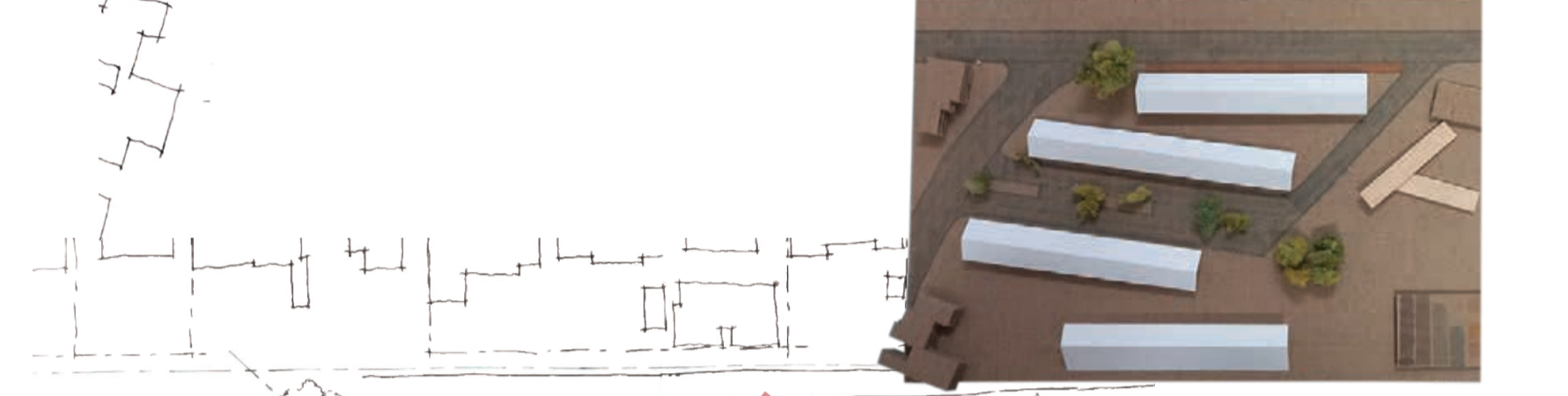
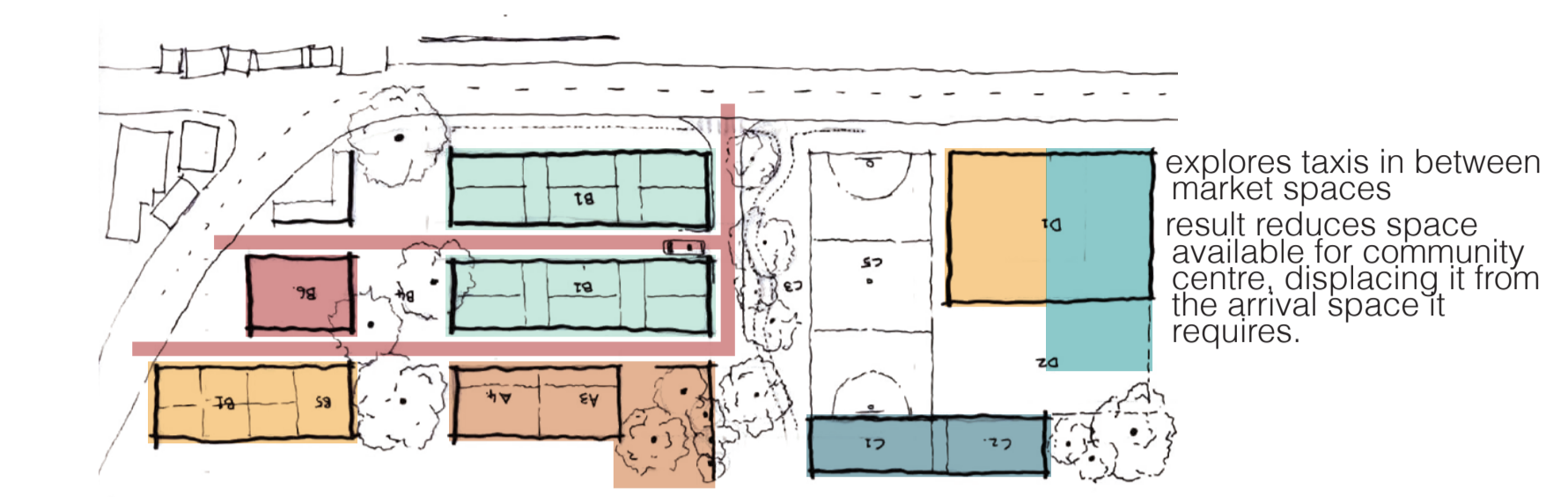

FLEXIBILITY AND MULTI-FUNCTIONALITY

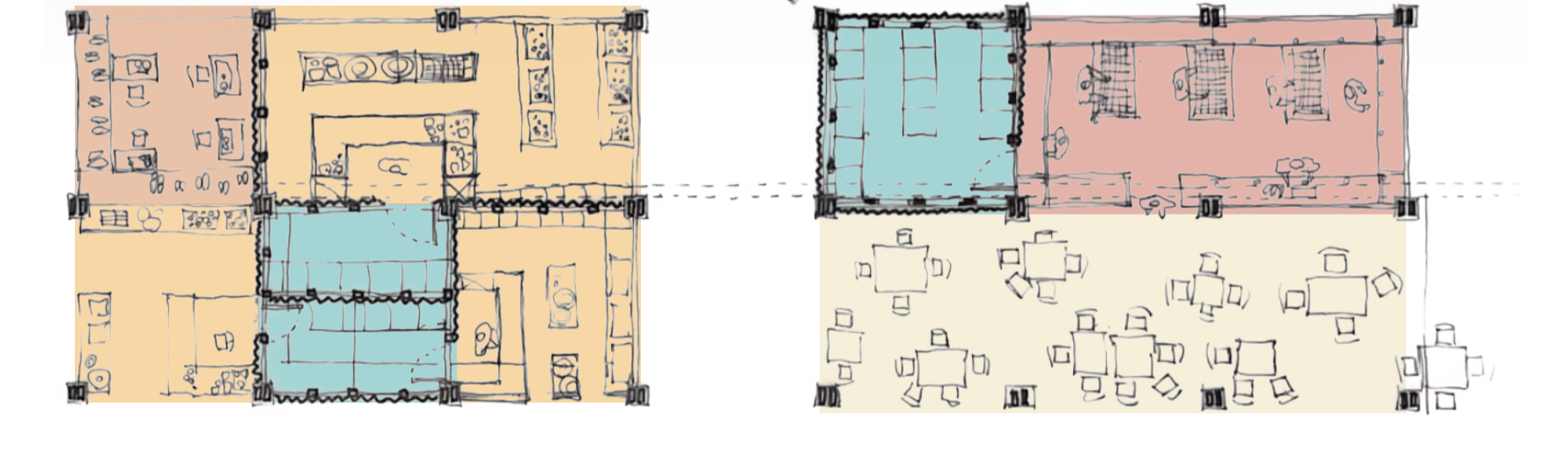
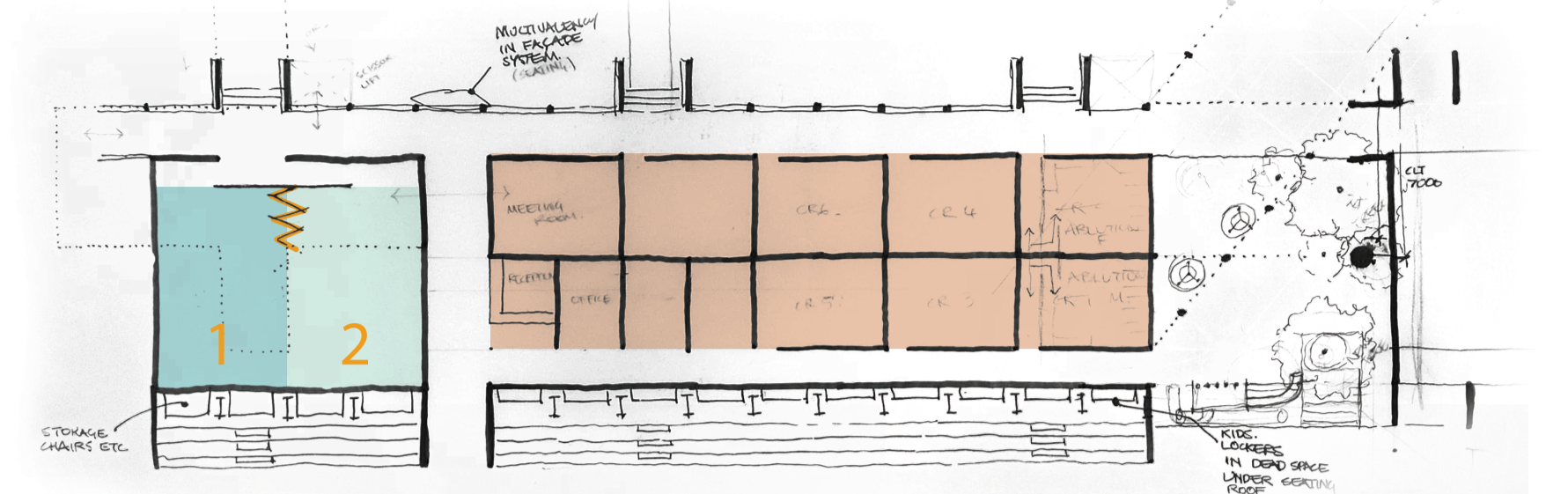

FORM FINDING

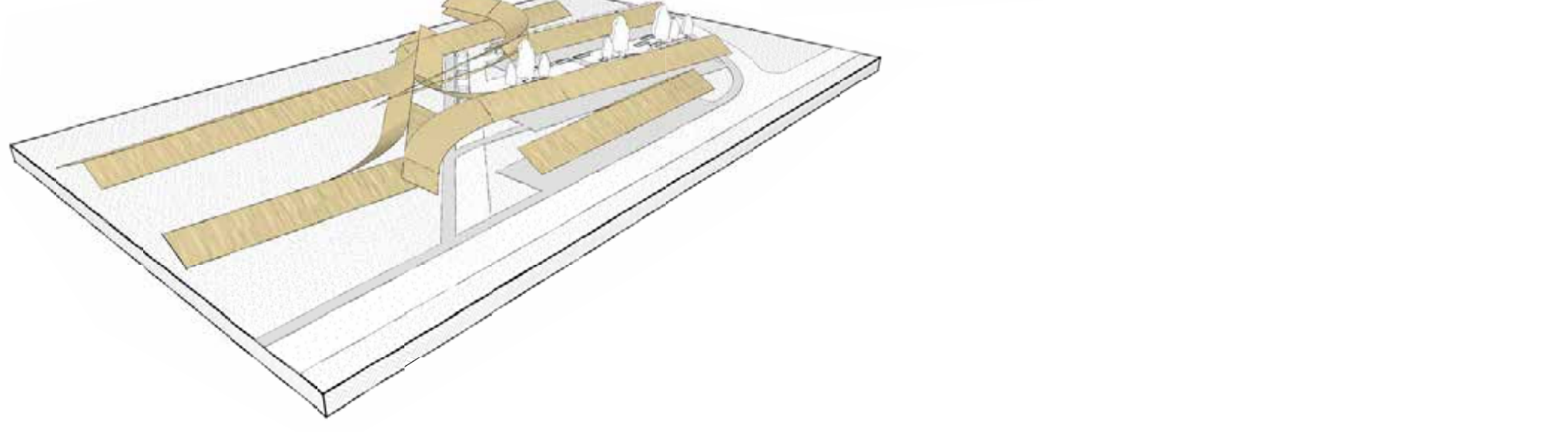
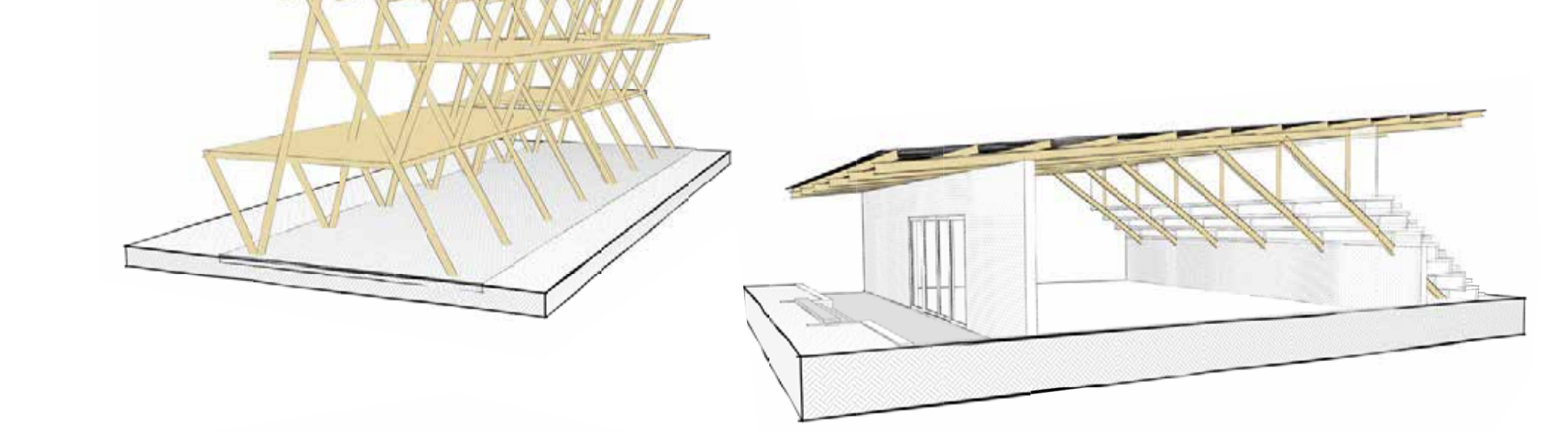
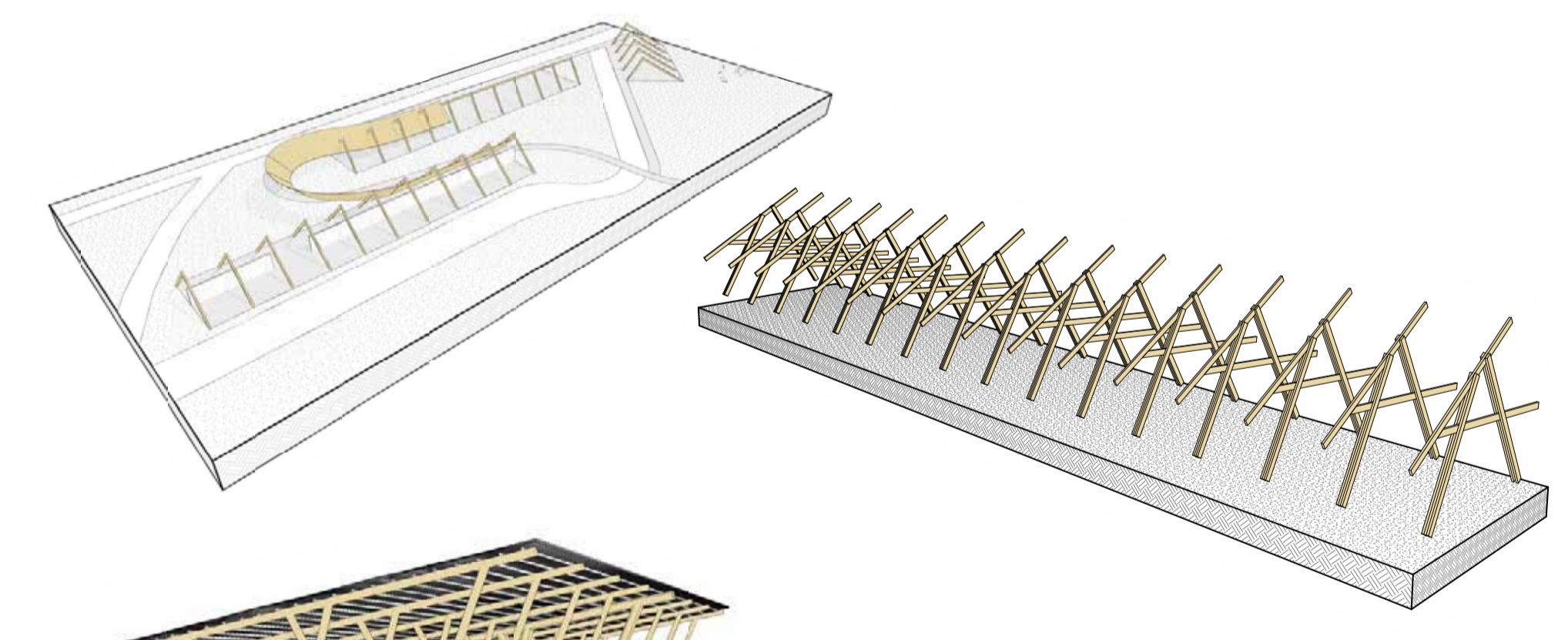

CONCEPTUALLY DEVELOPMENT

DESIGN CONCEPT

SCALES OF LAYERING AND MULTI-FUNCTIONALITY

Palimpsest

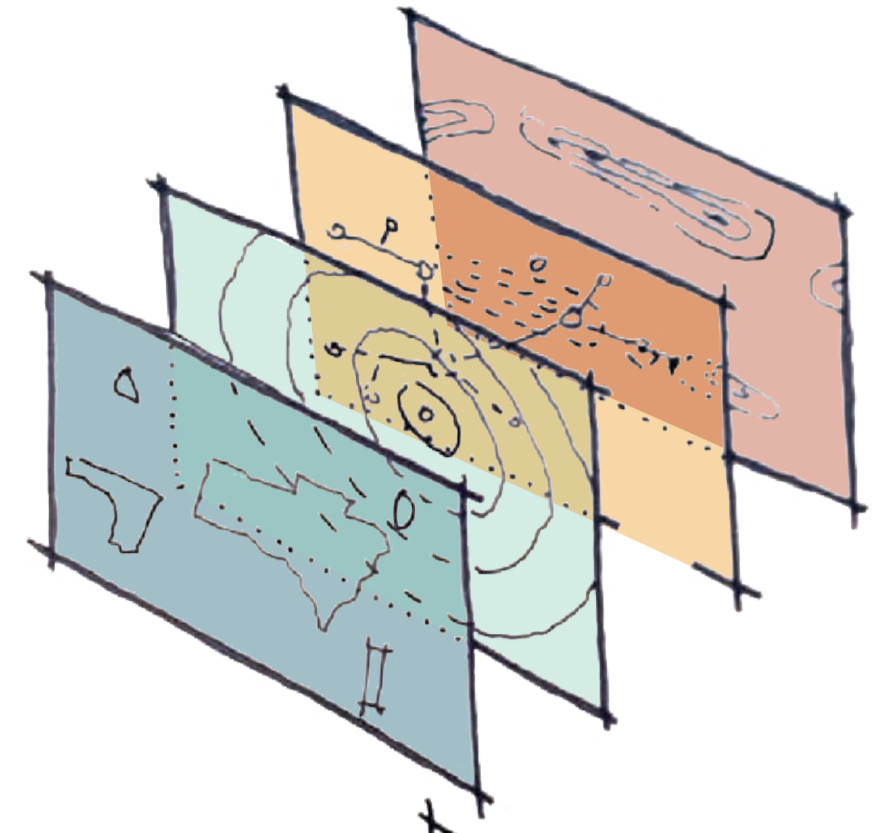

LAYERING:
transport networks
trading networks
culture
education
history
geography

Adaptive Facades

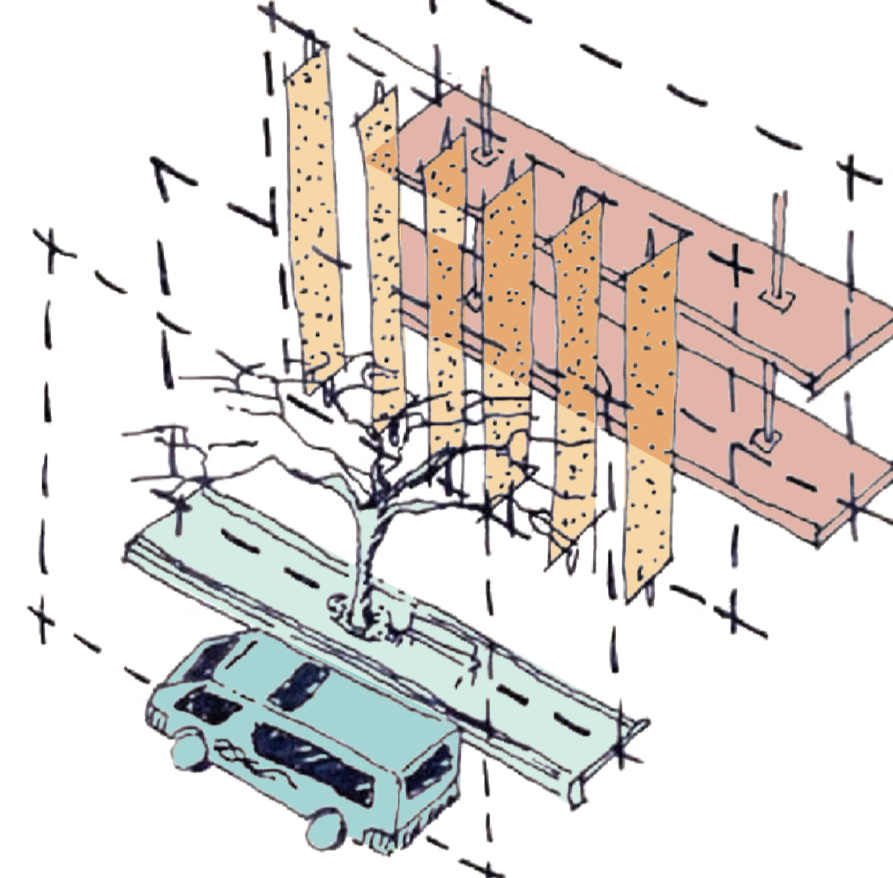

LAYERING:
creating thresholds
and gradient
visual stimulation
enabling empowerment
providing comfort
connection to landscape

Multivalency

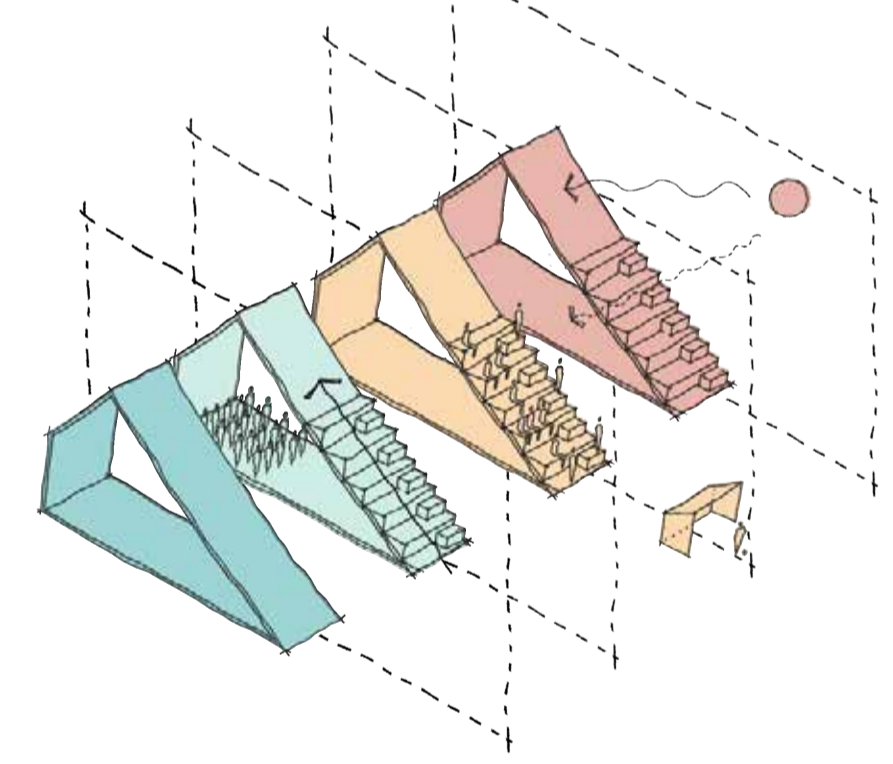

LAYERING:
spatial and
functional
built components
multi-use floor plans
future adaptation
climate control

KEY PRINCIPLES

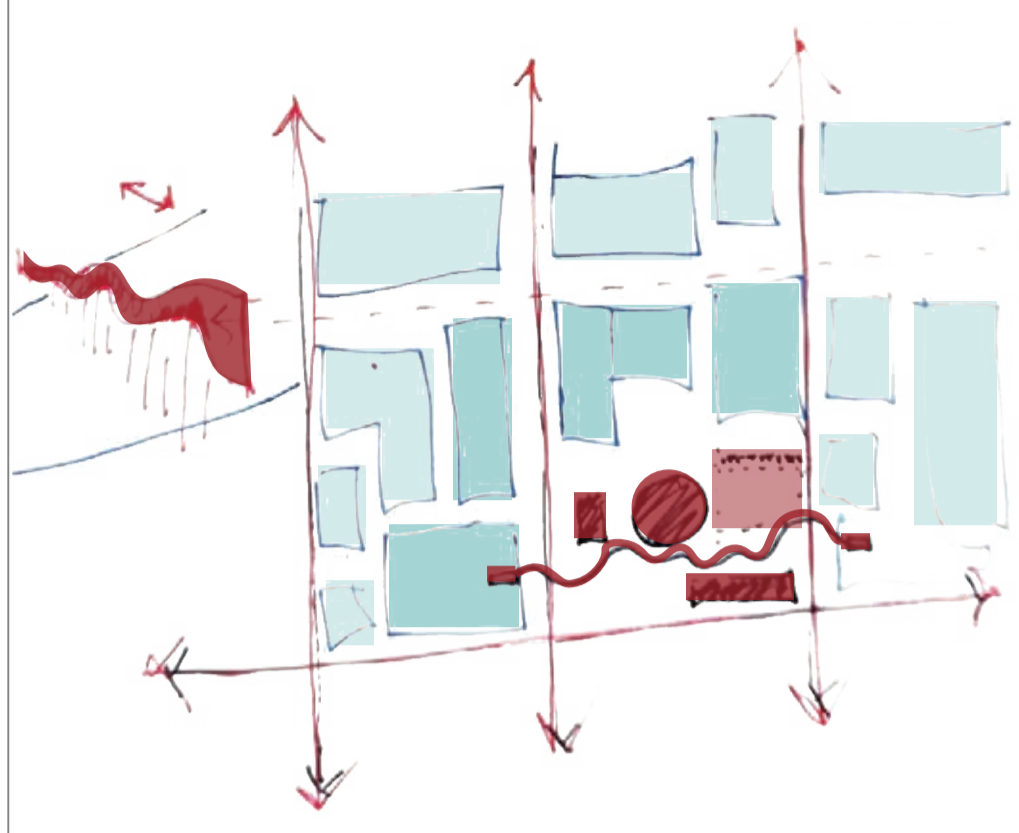

extent of inclusion
inviting / intriguing
introducing technology
climate responsive
thermal comfort
visual interest
threshold
envelope
rhythm
scale

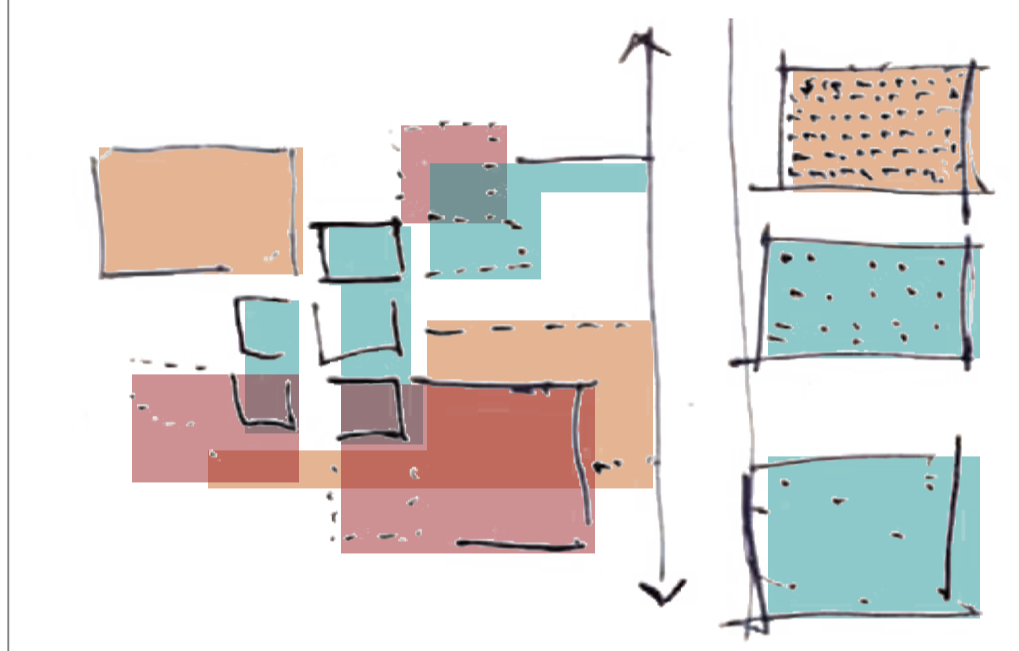

ability to change
socio-economic &
socio-ecological
uncertainty
facilitates stability
spatial datum
plasticity and
elasticity - malleable

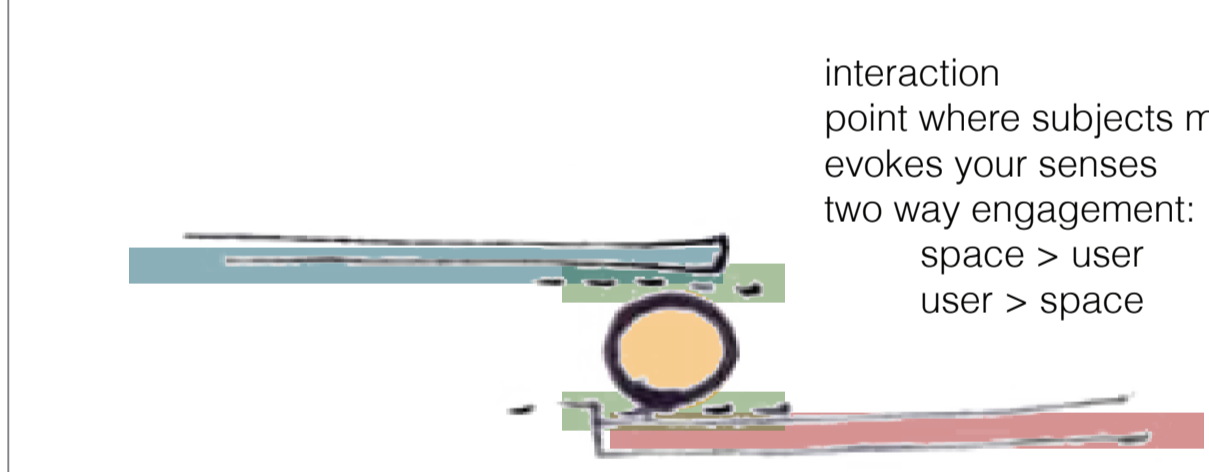

interaction
point where subjects meet
evokes your senses
two way engagement:
space > user
user > space

Facade

Adaptive
Capacity

Interface
and arrival

INFORMANTS

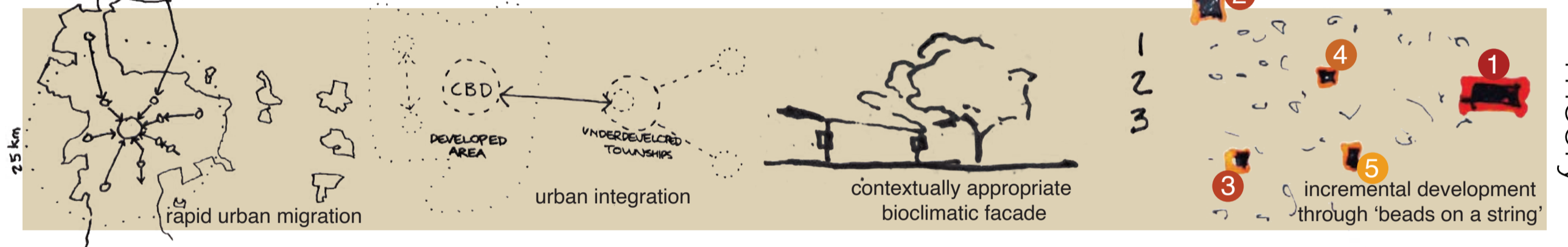
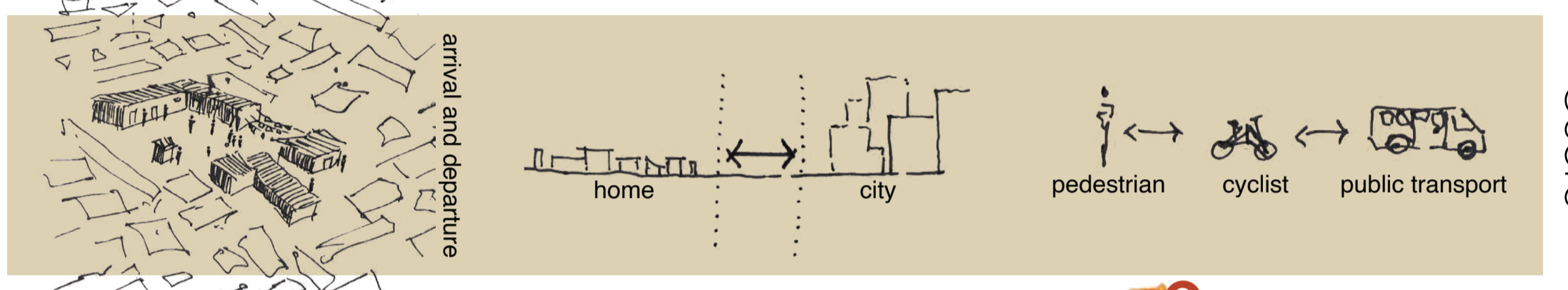
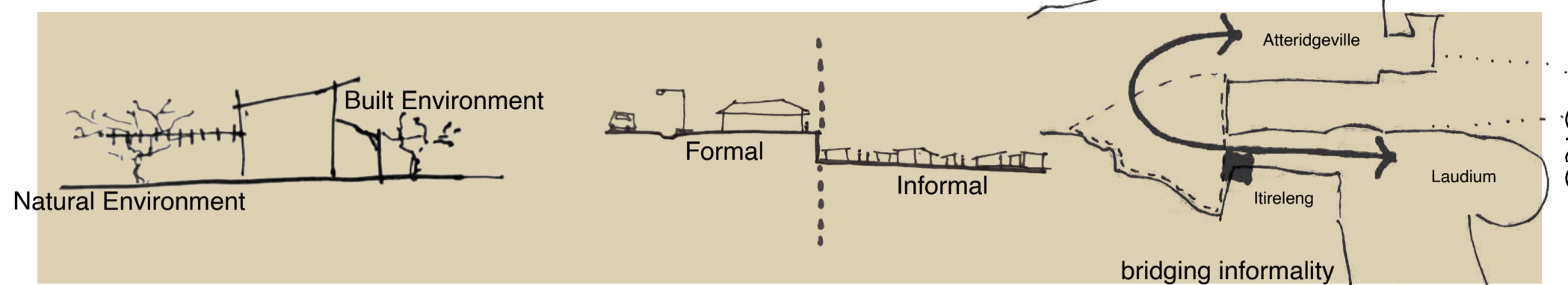

Site

Programme

Users

Theory

History

Flexibility to inform
Hierarchy and Movement

- non flexible
- semi flexible
- highly flexible

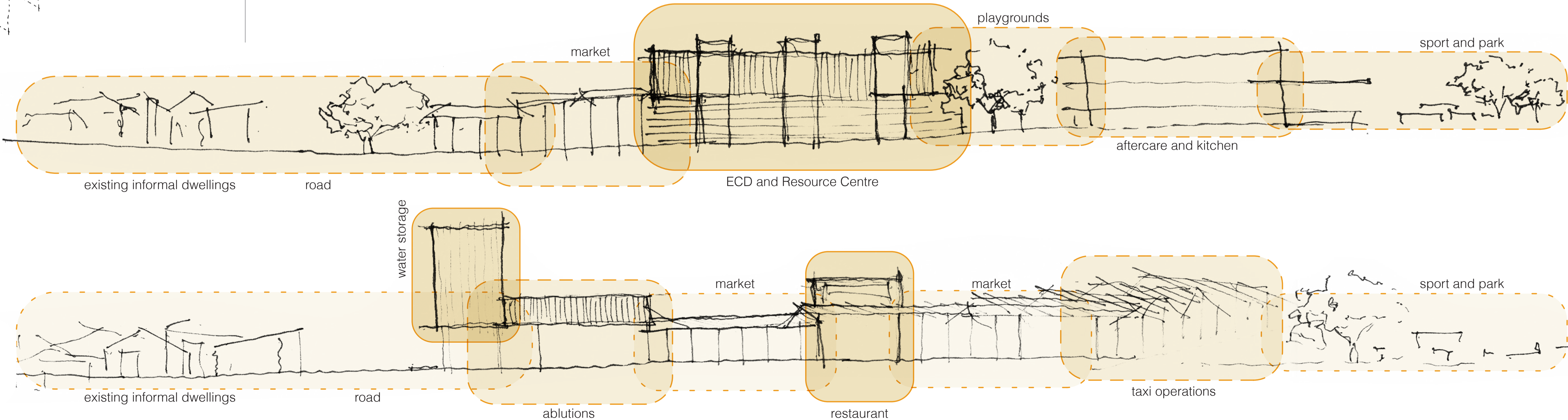

TECHNICAL CONCEPT

KEY PRINCIPLES

MULTIVALENCY

Where architectural elements are composed in a manner which not only enhances the spatial experience but increases resource efficiency and comfort. Built elements serve multiple purposes, creating the most architecture with the least amount of building.

MODULARITY

Design that allows standard sized building components to be retrofit to the primary structural components as required by the community. Allowing resilience through flexibility

DURABILITY

Material selection considers the heavy site usage adjacent to a taxi binding place. Columns are steel, as they are highly durable, allowing ease of assembly as opposed to creating form-work for concrete columns

LOCAL MATERIALS AND LABOUR

Concrete bricks and precast concrete components are produced adjacent to the site and will provide infill for ground floor walls and seating. First floor CLT floor and wall panels allows rapid lightweight, durable and more sustainable infill, clad with locally inspired corrugated sheeting.

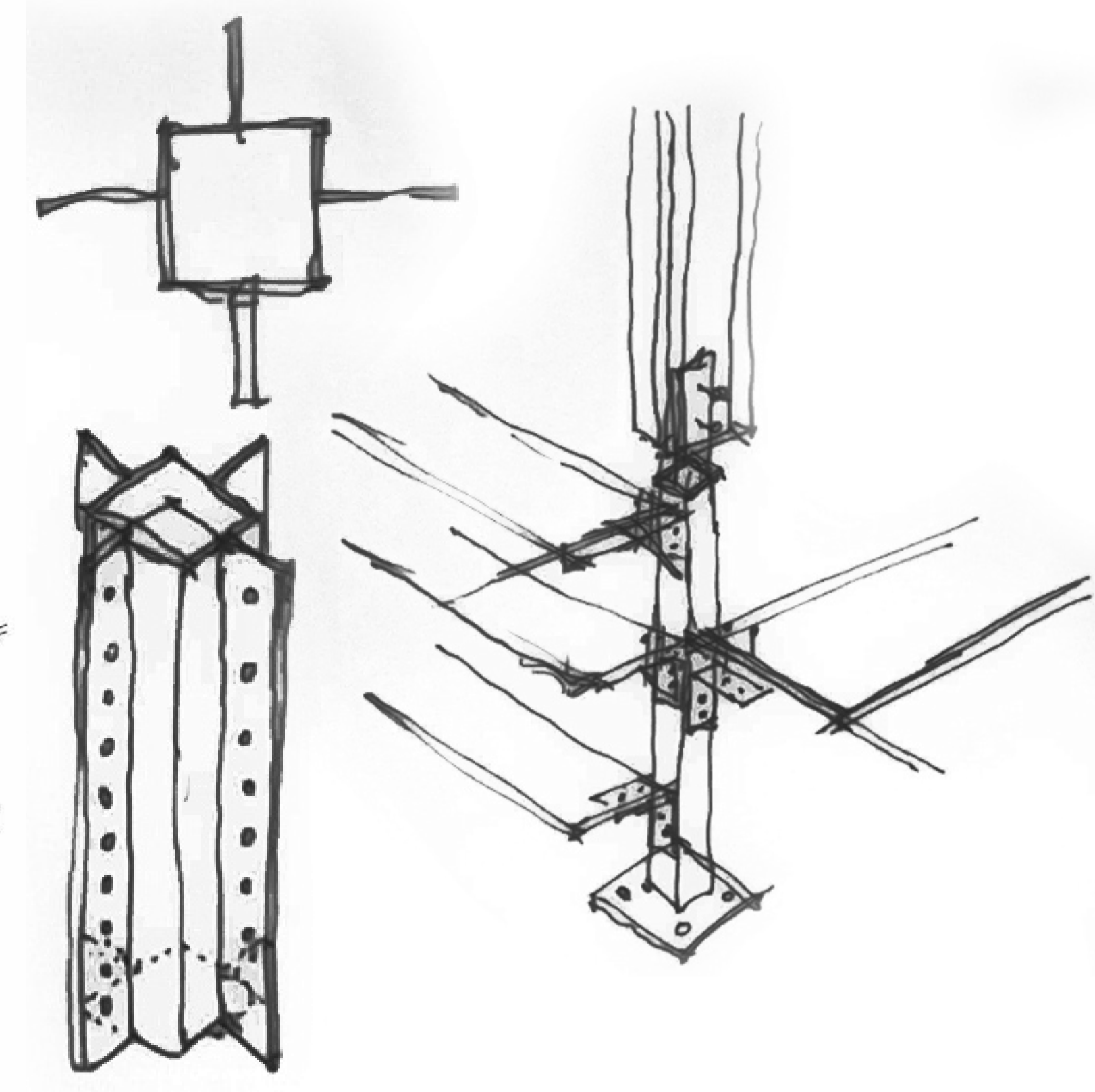
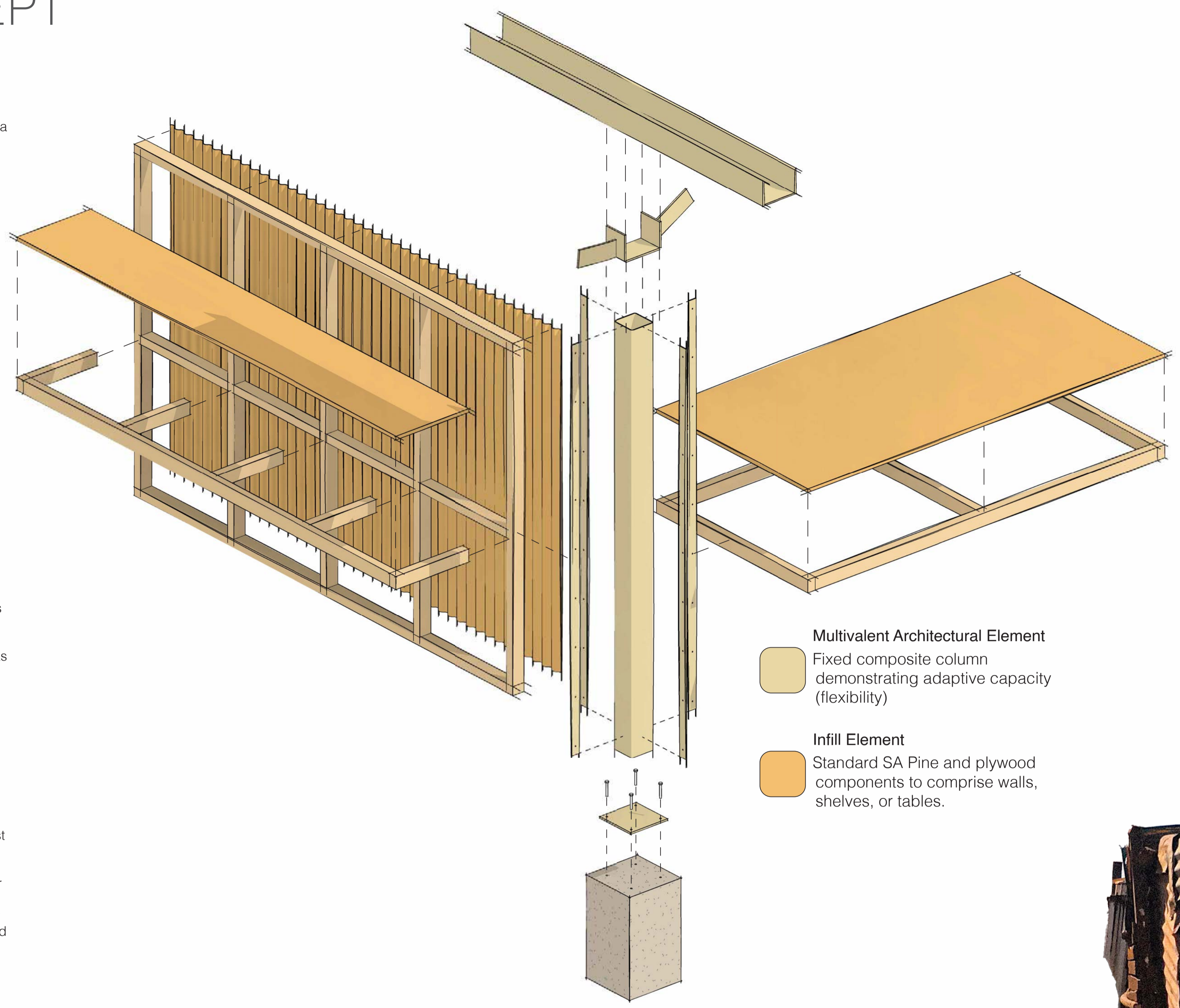

- Multivalent Architectural Element**
Fixed composite column demonstrating adaptive capacity (flexibility)
- Infill Element**
Standard SA Pine and plywood components to comprise walls, shelves, or tables.



PERFORMANCE ASSESSMENT

About the project:

The project's location serves as a gateway, or threshold, between formal and informal urban contexts, giving it a distinctly public nature. Residents must pass through this site to access the broader urban environment, making it a critical point of connection. Aligned with the theme of the "Right to the City," the project promotes equal access to urban opportunities for all residents. Key pillars such as transport, trade, culture, and education form the foundation of socio-economic agency within this space. To ensure these programs can thrive as catalysts for positive change, creating a safe and accessible environment is essential. This allows residents to engage fully with the opportunities presented, fostering community development and inclusion.

The need for a performance criteria:

The site currently exhibits characteristics typical of urban informal areas, where high crime rates contribute to unsafe daily living conditions. Out Line Road, which transitions into Military Road, has become particularly dangerous for pedestrians due to its largely undeveloped and poorly maintained streetscape. As a result, the pedestrian movement now exists on Bengal Street (one street north), where sidewalks are populated incorporating many elements that will be unpacked in the matrix. Key to its success, the site must accommodate multifunctional spaces, including an Early Childhood Development Centre (ECD), taxi ranks, markets, and business and vocational training facilities. Among these, the ECD becomes the focal point of this assessment due to its heightened vulnerability. By their nature, informal settlements lack the accessibility features typical of formal built environments, further segregating an already marginalised community. Thus, careful planning and thoughtful composition of built elements are essential to improve accessibility for all users.



ASSESSMENT CRITERIA: PUBLIC SAFETY

Deriving the performance criteria:

Performance criteria from theoretical and legislative sources are used to create a matrix for assessing the design strategy. This matrix categorizes public safety and accessibility into established subcategories, providing a holistic understanding of the building's inclusivity within its context.

The matrix identifies underperforming or missing design elements and refines key concepts through an iterative process. The criteria were developed by consulting reputable sources on creating safe, defensible spaces.

Key principles, guidelines, and case study lessons were grouped into a checklist, which was adapted into general indicators for the design. This synthesized knowledge from various sources into a cohesive set of criteria to achieve safety.

PUBLIC SAFETY

ACCESSIBILITY

Criteria	Reference	1	2	3	4	5	6	7	8	9	10	11	12	13	14	15	16	17	18	19	20	21	22	23	24	25	26	27	28	29	30	31	32	33	34	35	36	37	38	39	40	41	42	43	44	45	46	47	48	49	50	51	52	53	54	55	56	57	58	59	60	61	62	63	64	65	66	67	68	69	70	71	72	73	74	75	76	77	78	79	80	81	82	83	84	85	86	87	88	89	90	91	92	93	94	95	96	97	98	99	100
Is the road and footpath in the proposed location in good condition and free from potholes, cracks, and other surface defects?	South African Road Traffic Act 1989, 1993, 2002, 2008, 2010, 2012, 2014, 2015, 2017, 2019, 2020, 2021, 2022, 2023, 2024, 2025, 2026, 2027, 2028, 2029, 2030, 2031, 2032, 2033, 2034, 2035, 2036, 2037, 2038, 2039, 2040, 2041, 2042, 2043, 2044, 2045, 2046, 2047, 2048, 2049, 2050, 2051, 2052, 2053, 2054, 2055, 2056, 2057, 2058, 2059, 2060, 2061, 2062, 2063, 2064, 2065, 2066, 2067, 2068, 2069, 2070, 2071, 2072, 2073, 2074, 2075, 2076, 2077, 2078, 2079, 2080, 2081, 2082, 2083, 2084, 2085, 2086, 2087, 2088, 2089, 2090, 2091, 2092, 2093, 2094, 2095, 2096, 2097, 2098, 2099, 2100, 2101, 2102, 2103, 2104, 2105, 2106, 2107, 2108, 2109, 2110, 2111, 2112, 2113, 2114, 2115, 2116, 2117, 2118, 2119, 2120, 2121, 2122, 2123, 2124, 2125, 2126, 2127, 2128, 2129, 2130, 2131, 2132, 2133, 2134, 2135, 2136, 2137, 2138, 2139, 2140, 2141, 2142, 2143, 2144, 2145, 2146, 2147, 2148, 2149, 2150, 2151, 2152, 2153, 2154, 2155, 2156, 2157, 2158, 2159, 2160, 2161, 2162, 2163, 2164, 2165, 2166, 2167, 2168, 2169, 2170, 2171, 2172, 2173, 2174, 2175, 2176, 2177, 2178, 2179, 2180, 2181, 2182, 2183, 2184, 2185, 2186, 2187, 2188, 2189, 2190, 2191, 2192, 2193, 2194, 2195, 2196, 2197, 2198, 2199, 2200, 2201, 2202, 2203, 2204, 2205, 2206, 2207, 2208, 2209, 2210, 2211, 2212, 2213, 2214, 2215, 2216, 2217, 2218, 2219, 2220, 2221, 2222, 2223, 2224, 2225, 2226, 2227, 2228, 2229, 2230, 2231, 2232, 2233, 2234, 2235, 2236, 2237, 2238, 2239, 2240, 2241, 2242, 2243, 2244, 2245, 2246, 2247, 2248, 2249, 2250, 2251, 2252, 2253, 2254, 2255, 2256, 2257, 2258, 2259, 2260, 2261, 2262, 2263, 2264, 2265, 2266, 2267, 2268, 2269, 2270, 2271, 2272, 2273, 2274, 2275, 2276, 2277, 2278, 2279, 2280, 2281, 2282, 2283, 2284, 2285, 2286, 2287, 2288, 2289, 2290, 2291, 2292, 2293, 2294, 2295, 2296, 2297, 2298, 2299, 2300, 2301, 2302, 2303, 2304, 2305, 2306, 2307, 2308, 2309, 2310, 2311, 2312, 2313, 2314, 2315, 2316, 2317, 2318, 2319, 2320, 2321, 2322, 2323, 2324, 2325, 2326, 2327, 2328, 2329, 2330, 2331, 2332, 2333, 2334, 2335, 2336, 2337, 2338, 2339, 2340, 2341, 2342, 2343, 2344, 2345, 2346, 2347, 2348, 2349, 2350, 2351, 2352, 2353, 2354, 2355, 2356, 2357, 2358, 2359, 2360, 2361, 2362, 2363, 2364, 2365, 2366, 2367, 2368, 2369, 2370, 2371, 2372, 2373, 2374, 2375, 2376, 2377, 2378, 2379, 2380, 2381, 2382, 2383, 2384, 2385, 2386, 2387, 2388, 2389, 2390, 2391, 2392, 2393, 2394, 2395, 2396, 2397, 2398, 2399, 2400, 2401, 2402, 2403, 2404, 2405, 2406, 2407, 2408, 2409, 2410, 2411, 2412, 2413, 2414, 2415, 2416, 2417, 2418, 2419, 2420, 2421, 2422, 2423, 2424, 2425, 2426, 2427, 2428, 2429, 2430, 2431, 2432, 2433, 2434, 2435, 2436, 2437, 2438, 2439, 2440, 2441, 2442, 2443, 2444, 2445, 2446, 2447, 2448, 2449, 2450, 2451, 2452, 2453, 2454, 2455, 2456, 2457, 2458, 2459, 2460, 2461, 2462, 2463, 2464, 2465, 2466, 2467, 2468, 2469, 2470, 2471, 2472, 2473, 2474, 2475, 2476, 2477, 2478, 2479, 2480, 2481, 2482, 2483, 2484, 2485, 2486, 2487, 2488, 2489, 2490, 2491, 2492, 2493, 2494, 2495, 2496, 2497, 2498, 2499, 2500, 2501, 2502, 2503, 2504, 2505, 2506, 2507, 2508, 2509, 2510, 2511, 2512, 2513, 2514, 2515, 2516, 2517, 2518, 2519, 2520, 2521, 2522, 2523, 2524, 2525, 2526, 2527, 2528, 2529, 2530, 2531, 2532, 2533, 2534, 2535, 2536, 2537, 2538, 2539, 2540, 2541, 2542, 2543, 2544, 2545, 2546, 2547, 2548, 2549, 2550, 2551, 2552, 2553, 2554, 2555, 2556, 2557, 2558, 2559, 2560, 2561, 2562, 2563, 2564, 2565, 2566, 2567, 2568, 2569, 2570, 2571, 2572, 2573, 2574, 2575, 2576, 2577, 2578, 2579, 2580, 2581, 2582, 2583, 2584, 2585, 2586, 2587, 2588, 2589, 2590, 2591, 2592, 2593, 2594, 2595, 2596, 2597, 2598, 2599, 2600, 2601, 2602, 2603, 2604, 2605, 2606, 2607, 2608, 2609, 2610, 2611, 2612, 2613, 2614, 2615, 2616, 2617, 2618, 2619, 2620, 2621, 2622, 2623, 2624, 2625, 2626, 2627, 2628, 2629, 2630, 2631, 2632, 2633, 2634, 2635, 2636, 2637, 2638, 2639, 2640, 2641, 2642, 2643, 2644, 2645, 2646, 2647, 2648, 2649, 2650, 2651, 2652, 2653, 2654, 2655, 2656, 2657, 2658, 2659, 2660, 2661, 2662, 2663, 2664, 2665, 2666, 2667, 2668, 2669, 2670, 2671, 2672, 2673, 2674, 2675, 2676, 2677, 2678, 2679, 2680, 2681, 2682, 2683, 2684, 2685, 2686, 2687, 2688, 2689, 2690, 2691, 2692, 2693, 2694, 2695, 2696, 2697, 2698, 2699, 2700, 2701, 2702, 2703, 2704, 2705, 2706, 2707, 2708, 2709, 2710, 2711, 2712, 2713, 2714, 2715, 2716, 2717, 2718, 2719, 2720, 2721, 2722, 2723, 2724, 2725, 2726, 2727, 2728, 2729, 2730, 2731, 2732, 2733, 2734, 2735, 2736, 2737, 2738, 2739, 2740, 2741, 2742, 2743, 2744, 2745, 2746, 2747, 2748, 2749, 2750, 2751, 2752, 2753, 2754, 2755, 2756, 2757, 2758, 2759, 2760, 2761, 2762, 2763, 2764, 2765, 2766, 2767, 2768, 2769, 2770, 2771, 2772, 2773, 2774, 2775, 2776, 2777, 2778, 2779, 2780, 2781, 2782, 2783, 2784, 2785, 2786, 2787, 2788, 2789, 2790, 2791, 2792, 2793, 2794, 2795, 2796, 2797, 2798, 2799, 2800, 2801, 2802, 2803, 2804, 2805, 2806, 2807, 2808, 2809, 2810, 2811, 2812, 2813, 2814, 2815, 2816, 2817, 2818, 2819, 2820, 2821, 2822, 2823, 2824, 2825, 2826, 2827, 2828, 2829, 2830, 2831, 2832, 2833, 2834, 2835, 2836, 2837, 2838, 2839, 2840, 2841, 2842, 2843, 2844, 2845, 2846, 2847, 2848, 2849, 2850, 2851, 2852, 2853, 2854, 2855, 2856, 2857, 2858, 2859, 2860, 2861, 2862, 2863, 2864, 2865, 2866, 2867, 2868, 2869, 2870, 2871, 2872, 2873, 2874, 2875, 2876, 2877, 2878, 2879, 2880, 2881, 2882, 2883, 2884, 2885, 2886, 2887, 2888, 2889, 2890, 2891, 2892, 2893, 2894, 2895, 2896, 2897, 2898, 2899, 2900, 2901, 2902, 2903, 2904, 2905, 2906, 2907, 2908, 2909, 2910, 2911, 2912, 2913, 2914, 2915, 2916, 2917, 2918, 2919, 2920, 2921, 2922, 2923, 2924, 2925, 2926, 2927, 2928, 2929, 2930, 2931, 2932, 2933, 2934, 2935, 2936, 2937, 2938, 2939, 2940, 2941, 2942, 2943, 2944, 2945, 2946, 2947, 2948, 2949, 2950, 2951, 2952, 2953, 2954, 2955, 2956, 2957, 2958, 2959, 2960, 2961, 2962, 2963, 2964, 2965, 2966, 2967, 2968, 2969, 2970, 2971, 2972, 2973, 2974, 2975, 2976, 2977, 2978, 2979, 2980, 2981, 2982, 2983, 2984, 2985, 2986, 2987, 2988, 2989, 2990, 2991, 2992, 2993, 2994, 2995, 2996, 2997, 2998, 2999, 3000, 3001, 3002, 3003, 3004, 3005, 3006, 3007, 3008, 3009, 3010, 3011, 3012, 3013, 3014, 3015, 3016, 3017, 3018, 3019, 3020, 3021, 3022, 3023, 3024, 3025, 3026, 3027, 3028, 3029, 3030, 3031, 3032, 3033, 3034, 3035, 3036, 3037, 3038, 3039, 3040, 3041, 3042, 3043, 3044, 3045, 3046, 3047, 3048, 3049, 3050, 3051, 3052, 3053, 3054, 3055, 3056, 3057, 3058, 3059, 3060, 3061, 3062, 3063, 3064, 3065, 3066, 3067, 3068, 3069, 3070, 3071, 3072, 3073, 3074, 3075, 3076, 3077, 3078, 3079, 3080, 3081, 3082, 3083, 3084, 3085, 3086, 3087, 3088, 3089, 3090, 3091, 3092, 3093, 3094, 3095, 3096, 3097, 3098, 3099, 3100, 3101, 3102, 3103, 3104, 3105, 3106, 3107, 3108, 3109, 3110, 3111, 3112, 3113, 3114, 3115, 3116, 3117, 3118, 3119, 3120, 3121, 3122, 3123, 3124, 3125, 3126, 3127, 3128, 3129, 3130, 3131, 3132, 3133, 3134, 3135, 3136, 3137, 3138, 3139, 3140, 3141, 3142, 3143, 3144, 3145, 3146, 3147, 3148, 3149, 3150, 3151, 3152, 3153, 3154, 3155, 3156, 3157, 3158, 3159, 3160, 3161, 3162, 3163, 3164, 3165, 3166, 3167, 3168, 3169, 3170, 3171, 3172, 3173, 3174, 3175, 3176, 3177, 3178, 3179, 3180, 3181, 3182, 3183, 3184, 3185, 3186, 3187, 3188, 3189, 3190, 3191, 3192, 3193, 3194, 3195, 3196, 3197, 3198, 3199, 3200, 3201, 3202, 3203, 3204, 3205, 3206, 3207, 3208, 3209, 3210, 3211, 3212, 3213, 3214, 3215, 3216, 3217, 3218, 3219, 3220, 3221, 3222, 3223, 3224, 3225, 3226, 3227, 3228, 3229, 3230, 3231, 3232, 3233, 3234, 3235, 3236, 3237, 3238, 3239, 3240, 3241, 3242, 3243, 3244, 3245, 3246, 3247, 3248, 3249, 3250, 3251, 3252, 3253, 3254, 3255, 3256, 3257, 3258, 3259, 3260, 3261, 3262, 3263, 3264, 3265, 3266, 3267, 3268, 3269, 3270, 3271, 3272, 3273, 3274, 3275, 3276, 3277, 3278, 3279, 3280, 3281, 3282, 3283, 3284, 3285, 3286, 3287, 3288, 3289, 3290, 3291, 3292, 3293, 3294, 3295, 3296, 3297, 3298, 3299, 3300, 3301, 3302, 3303, 3304, 3305, 3306, 3307, 3308, 3309, 3310, 3311, 3312, 3313, 3314, 3315, 3316, 3317, 3318, 3319, 3320, 3321, 3322, 3323, 3324, 3325, 3326, 3327, 3328, 3329, 3330, 3331, 3332, 3333, 3334, 3335, 3336, 3337, 3338, 3339, 3340, 3341, 3342, 3343, 3344, 3345, 3346, 3347, 3348, 3349, 3350, 3351, 3352, 3353, 3354, 3355, 3356, 3357, 3358, 3359, 3360, 3361, 3362, 3363, 3364, 3365, 3366, 3367, 3368, 3369, 3370, 3371, 3372, 3373, 3374, 3375, 3376, 3377, 3378, 3379, 3380, 3381, 3382, 3383, 3384, 3385, 3386, 3387, 3388, 3389, 3390, 3391, 3392, 3393, 3394, 3395, 3396, 3397, 3398, 3399, 3400, 3401, 3402, 3403, 3404, 3405, 3406, 3407, 3408, 3409, 3410, 3411, 3412, 3413, 3414, 3415, 3416, 3417, 3418, 3419, 3420, 3421, 3422, 3423, 3424, 3425, 3426, 3427, 3428, 3429, 3430, 3431, 3432, 3433, 3434, 3435, 3436, 3437, 3438, 3439, 3440, 3441, 3442, 3443, 3444, 3445, 3446, 3447, 3448, 3449, 3450, 3451, 3452, 3453, 3454, 3455, 3456, 3457, 3458, 3459, 3460, 3461, 3462, 3463, 3464, 3465, 3466, 3467, 3468, 3469, 3470, 3471, 3472, 3473, 3474, 3475, 3476, 3477, 3478, 3479, 3480, 3481, 3482, 3483, 3484, 3485, 3486, 3487, 3488, 3489, 3490, 3491, 3492, 3493, 3494, 3495, 3496, 3497, 3498, 3499, 3500, 3501, 3502, 3503, 3504, 3505, 3506, 3507, 3508, 3509, 3510, 3511, 3512, 3513, 3514, 3515, 3516, 3517, 3518, 3519, 3520, 3521, 3522, 3523, 3524, 3525, 3526, 3527, 3528, 3529, 3530, 3531, 3532, 3533, 3534, 3535, 3536, 3537, 3538, 3539, 3540, 3541, 3542, 3543, 3544, 3545, 3546, 3547, 3548, 3549, 3550, 3551, 3552, 3553, 3554, 3555, 3556, 3557, 3558, 3559, 3560, 3561, 3562, 3563, 3564, 3565, 3566, 3567, 3568, 3569, 3570, 3571, 3572, 3573, 3574, 3575, 3576, 3577, 3578, 3579, 3580, 3581, 3582, 3583, 3584, 3585, 3586, 3587, 3588, 3589, 3590, 3591, 3592, 3593, 3594, 3595, 3596, 3597, 3598, 3599, 3600, 3601, 3602, 3603, 3604, 3605, 3606, 3607, 3608, 3609, 3610, 3611, 3612, 3613, 3614, 3615, 3616, 3617, 3618, 3619, 3620, 3621, 3622, 3623, 3624, 3625, 3626, 3627, 3628, 3629, 3630, 3631, 3632, 3633, 3634, 3635, 3636, 3637, 3638, 3639, 3640, 3641, 3642, 3643, 3644, 3645, 3646, 3647, 3648, 3649, 3650, 3651, 3652, 3653, 3654, 3655, 3656, 3657, 3658, 3659, 3660, 3661, 3662, 3663, 3664, 3665, 3666, 3667, 3668, 3669, 3670, 3671, 3672, 3673, 3674, 3675, 3676, 3677, 3678, 3679, 3680, 3681, 3682, 3683, 3684, 3685, 3686, 3687, 3688, 3689, 3690, 3691, 3692, 3693, 3694, 3695, 3696, 3697, 3698, 3699, 3700, 3701, 3702, 3703, 3704, 3705, 3706, 3707, 3708, 3709, 3710, 3711, 3712, 3713, 3714, 3715, 3716, 3717, 3718, 3719, 3720, 3721, 3722, 3723, 3724, 3725, 3726, 3727, 3728, 3729, 3730, 3731, 3732, 3733, 3734, 3735, 3736, 3737, 3738, 3739, 3740, 3741, 3742, 3743, 3744, 3745, 3746, 3747, 3748, 3749, 3750, 3751, 3752, 3753, 3754, 3755, 3756, 3757, 3758, 3759, 3760, 376																																																																																																				

CRITERIA APPLICATION

About the project:

The current site in Itereleng displays some levels of safety and accessibility. The current ECD is positioned in the center of the site where it can be accessed from all sides. A fence was put up to enforce some measure of security while creating access points. Surrounding level changes are abrupt, the road lacks sidewalks to direct pedestrian traffic safely. Some of the street lighting still exists along the road. There are also instances of shading and benches to create pleasant spaces for residents to wait.

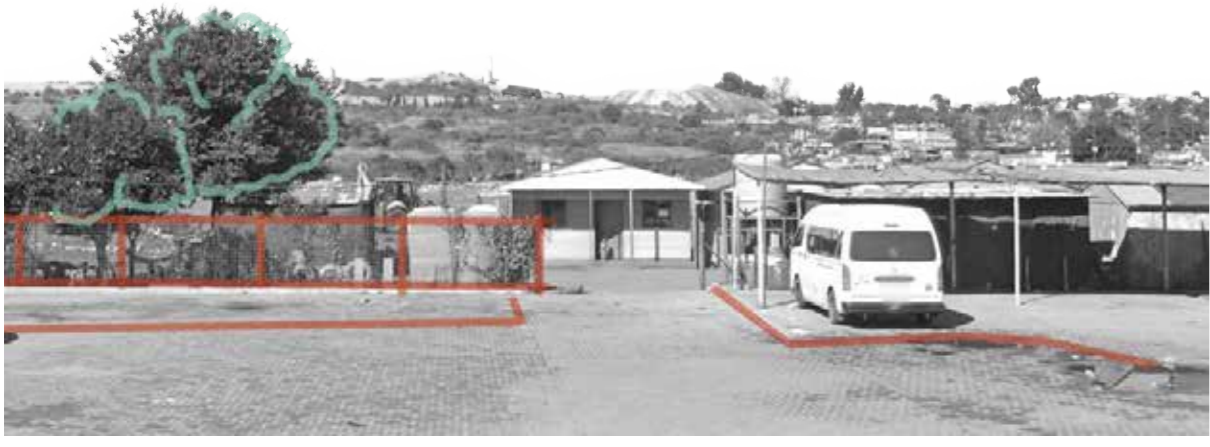

Project portion under assessment

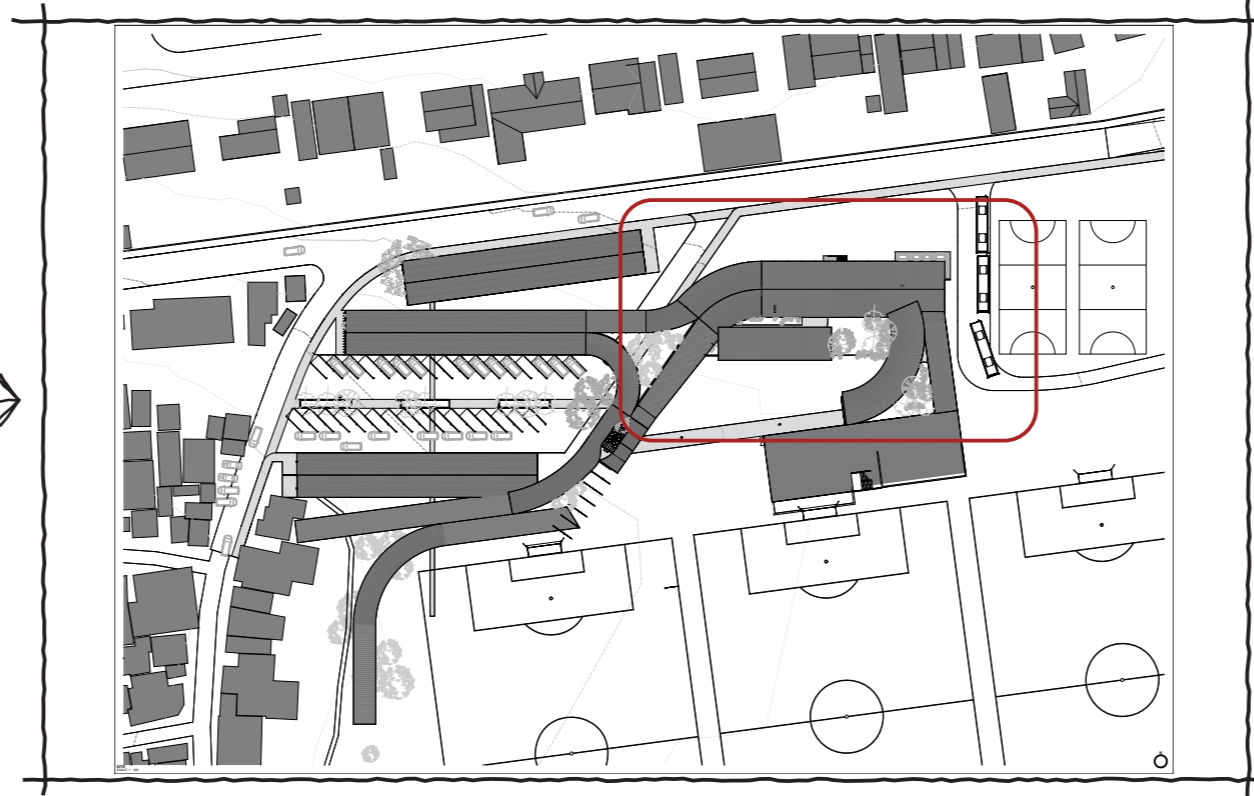
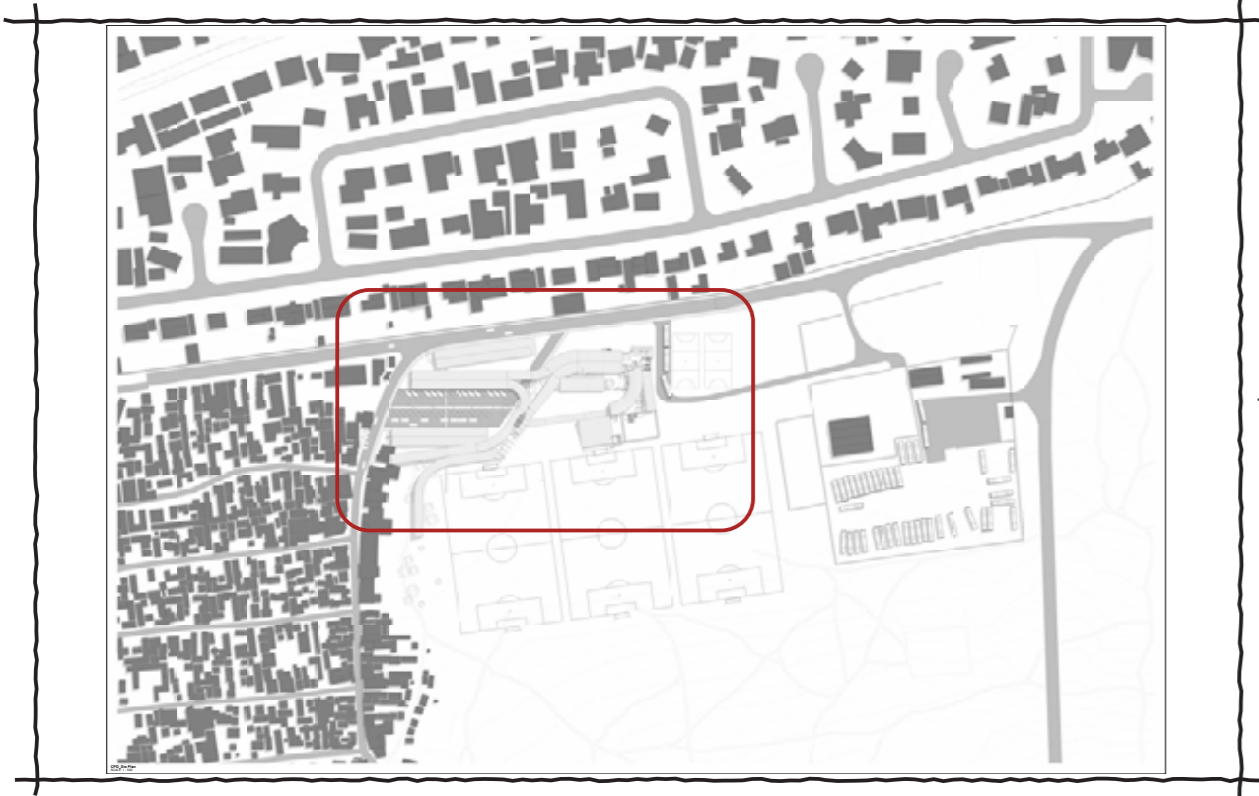

Floor Plan of current design

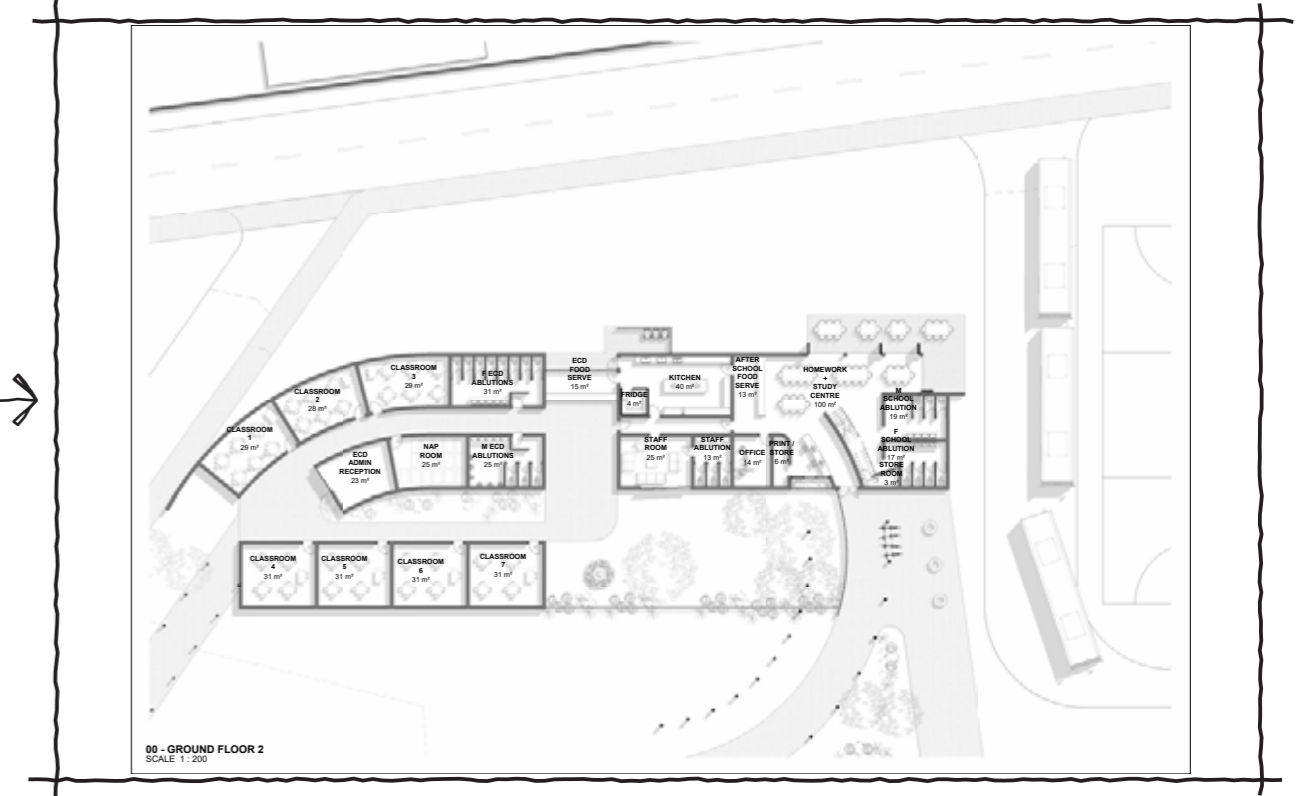

Area of focus

DESIGN EVOLUTION

Base Case:

Focus: determine success of current design

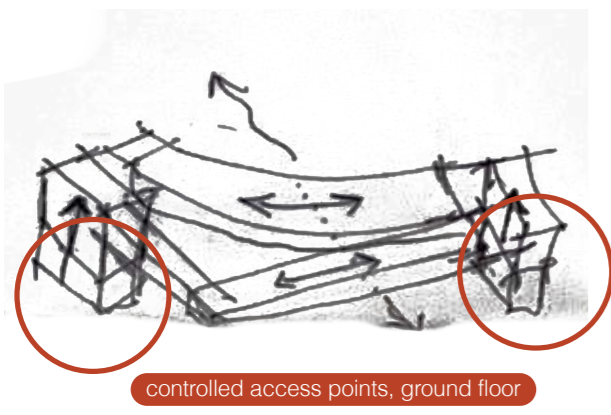
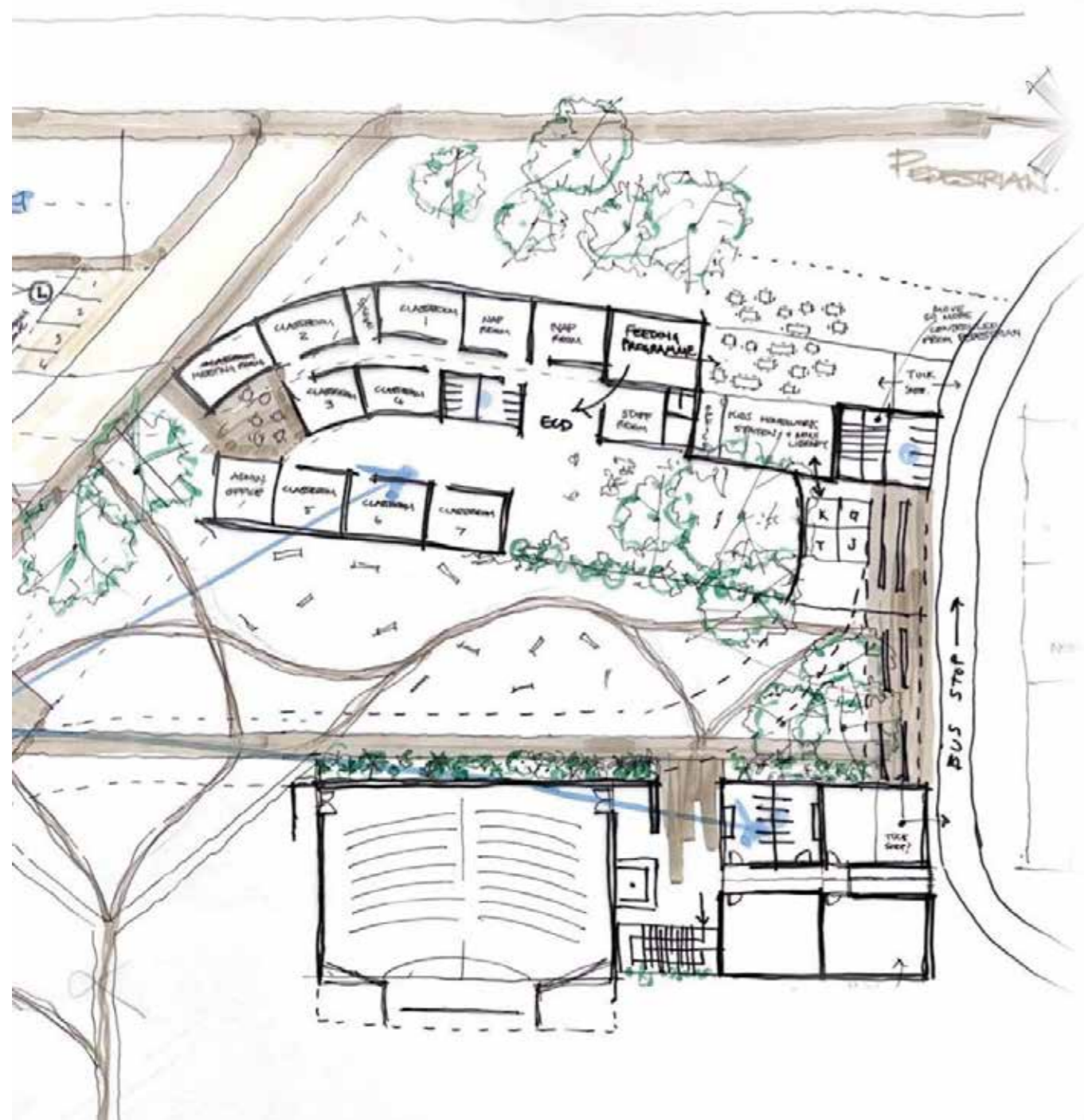

controlled access points, ground floor

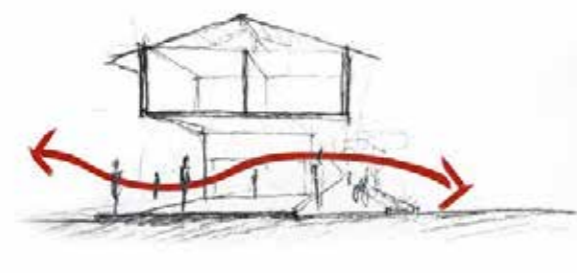

pedestrianised ground floor, street edge, accessibility

Iteration 2:

Focus: identify and improve problem areas according to matrix

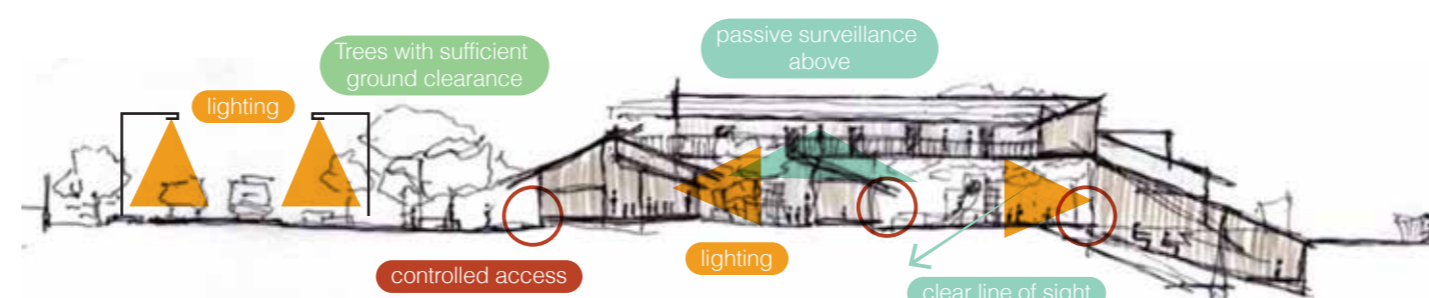
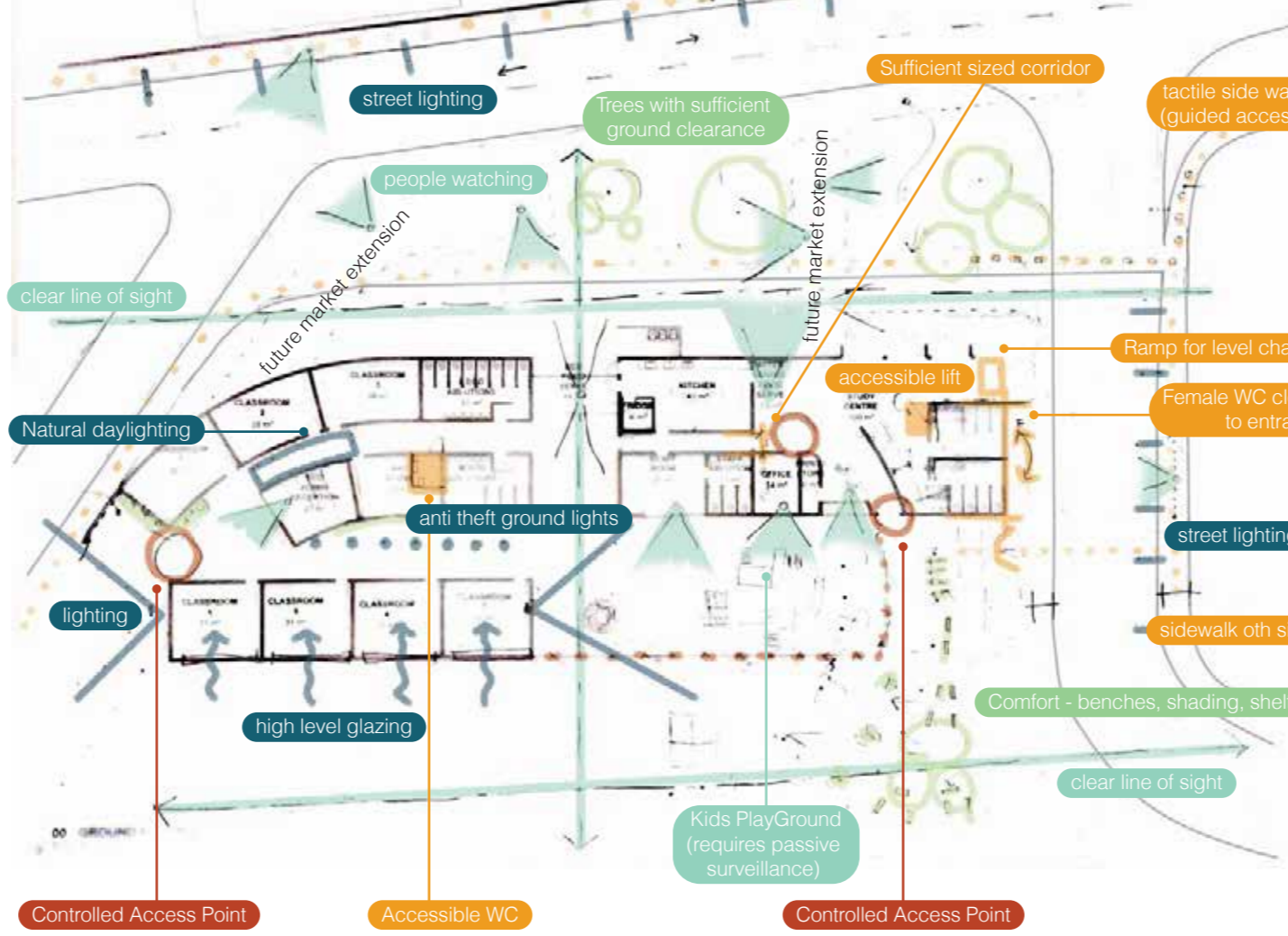

controlled access, lighting, passive surveillance above, clear line of sight

Iteration 3:

Focus: further refinement and distillation of key concepts unpacked

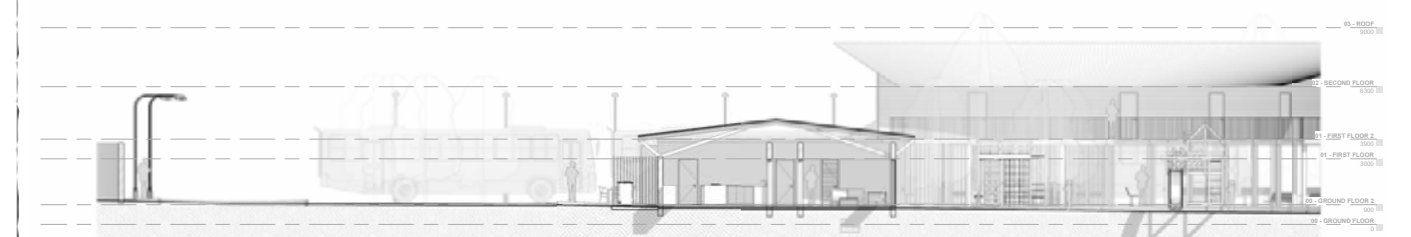
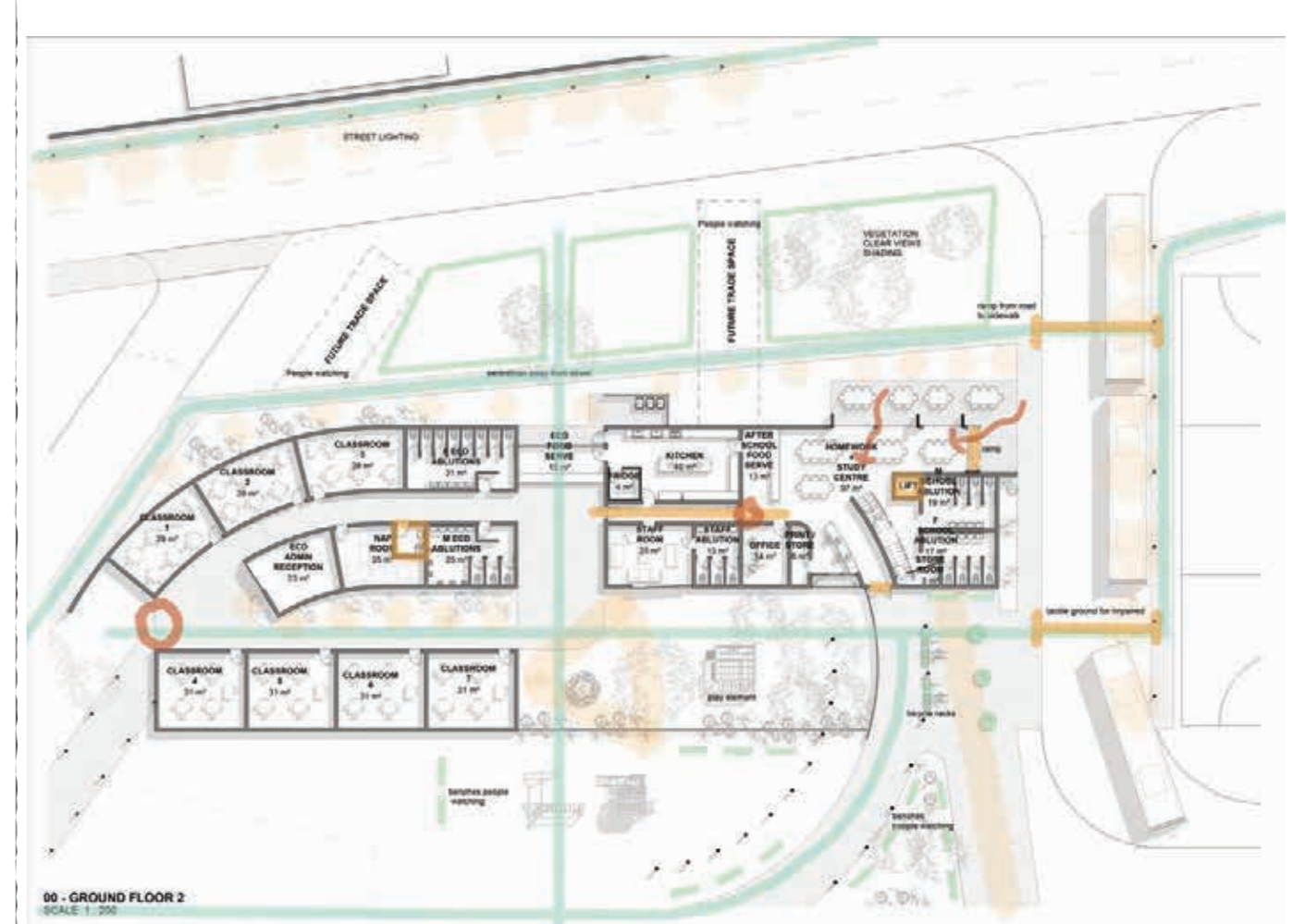

Reflection 1

Upon analysing the performance of the base case, it became clear that the design required a significant amount of attention to address the performance regarding overall inclusivity.

The iteration scored:
Public Safety: 34 / 100
Accessibility: 29 / 100

Inclusivity: 31,5 / 100

Reflection 2

After identifying problem areas, and distilling the target areas major improvement resulted, where the design still lacked in accessible ablutions, lifts, public lighting as well as comfort.

The iteration scored:
Public Safety: 73 / 100
Accessibility: 63 / 100

Inclusivity: 68 / 100

Reflection 3

The final iteration further increased the inclusivity figure, where more consideration and resolution was given to accessible ablutions as well as pedestrian movement while incorporating tactile paving, and ramped transitions from road to sidewalk. Additional sidewalks are added and the overall movement network improved. Lastly, lighting is included in all public areas.

The iteration scored:
Public Safety: 90 / 100
Accessibility: 76 / 100

Inclusivity: 83 / 100

WATER HARVESTING

Average Water Yield			Average Local Rainfall	
Month	Average monthly Precipitation, P (m)	Yield (m ³) = P x A x C	Month	Average monthly Precipitation (mm)
January	0,137	228,67	January	137
February	0,07	116,84	February	70
March	0,081	135,20	March	81
April	0,044	73,44	April	44
May	0,016	26,71	May	16
June	0,012	20,03	June	12
July	0	0,00	July	0
August	0,003	5,01	August	3
September	0,028	46,74	September	28
October	0,068	113,50	October	68
November	0,088	146,89	November	88
December	0,123	205,31	December	123
Annual Average	0,07	1110,33		

Roof Catchment area = 1669,15m²
Run-off coefficient (steel roof) = 0,8
Run-off coefficient for suburban areas = 0,65

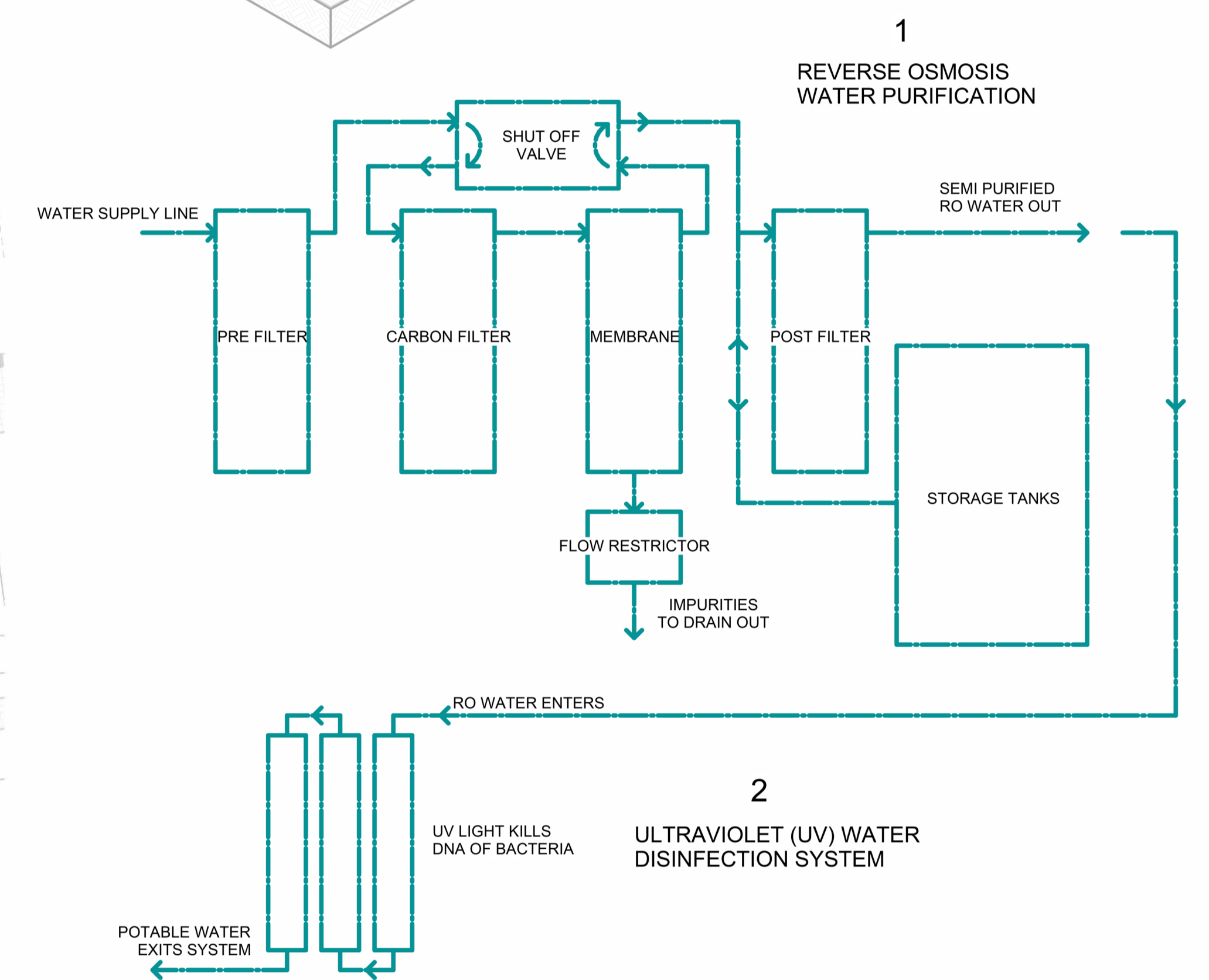
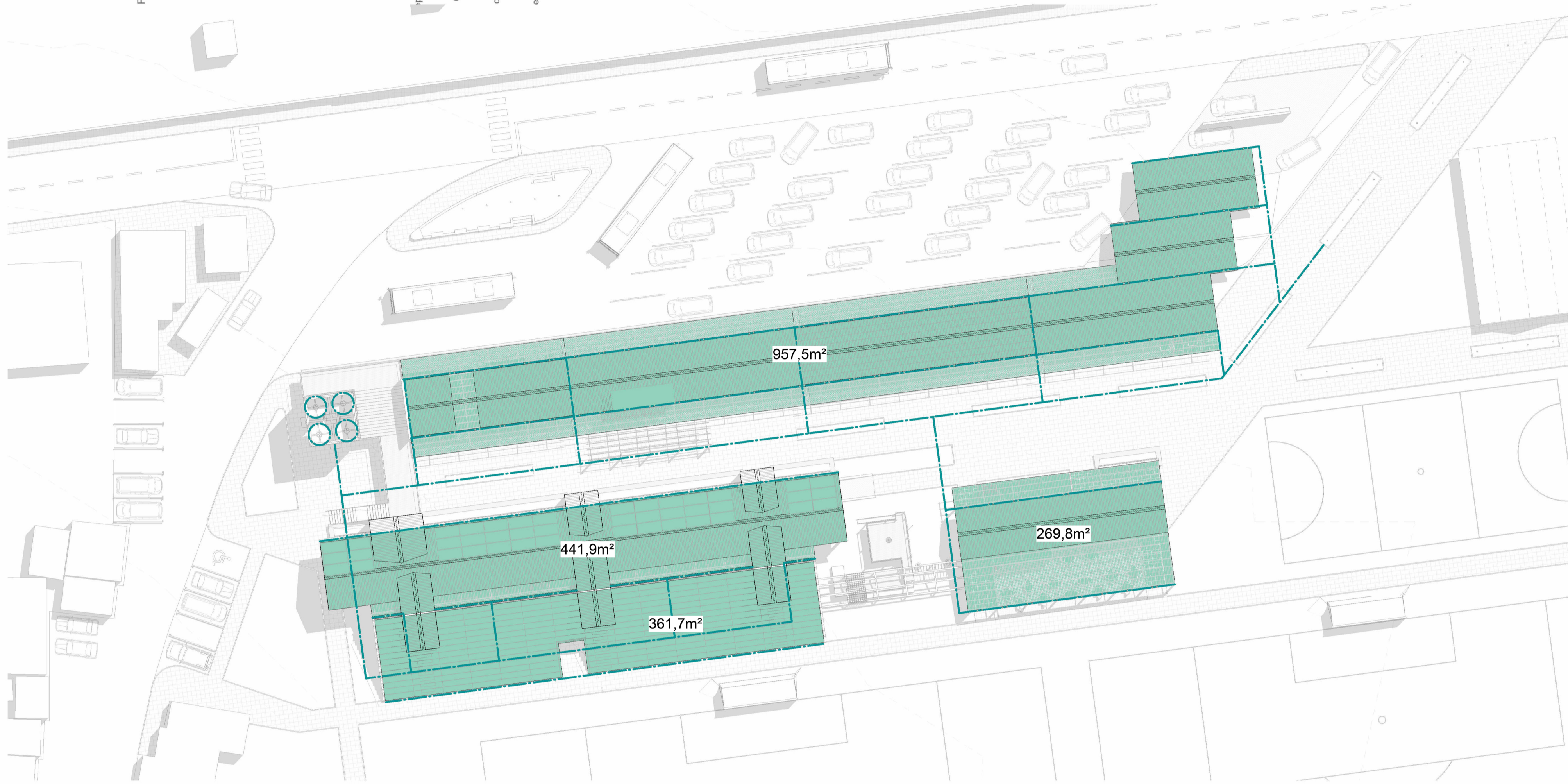
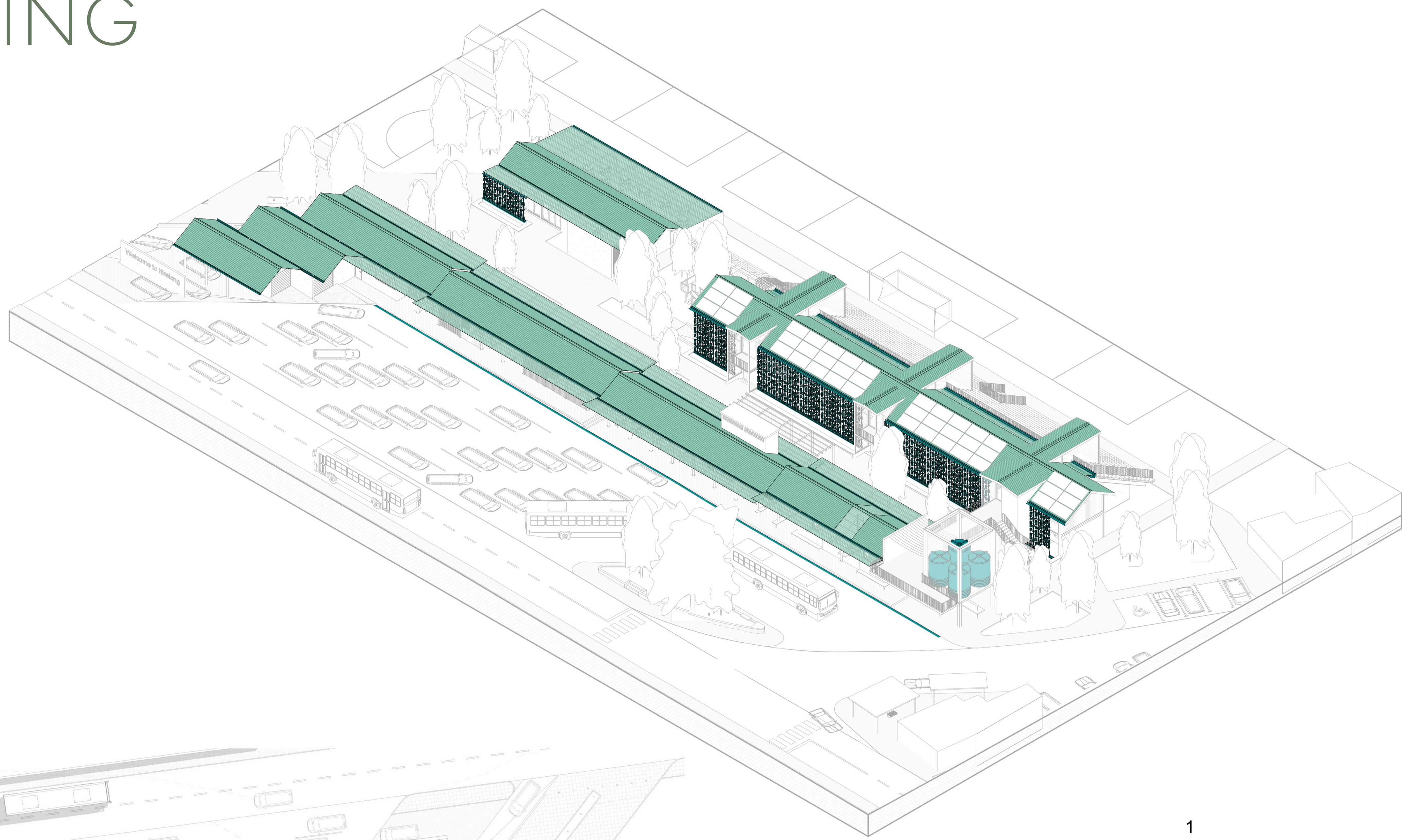
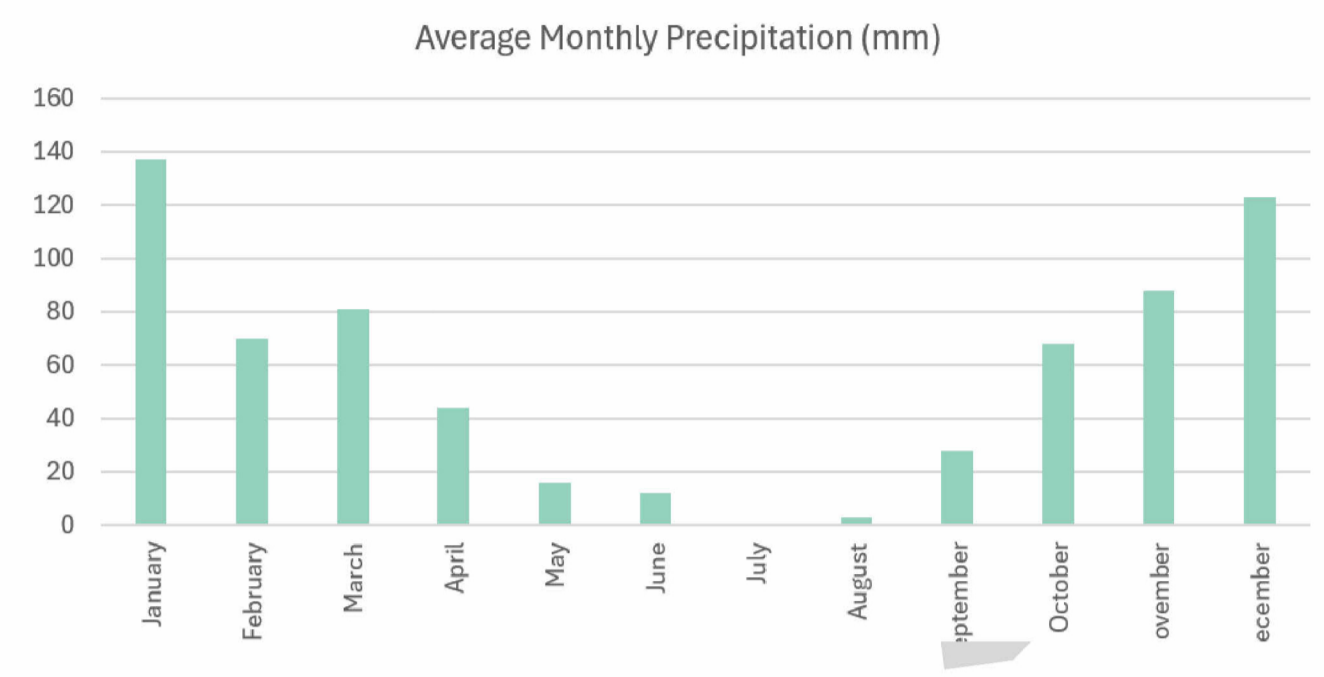

SOLAR AND LIGHTING

